



Rotary Encoders

R35i
RCML15

RENCO R35i and RCML15 Rotary Encoders

The **RENCO R35i** is an incremental rotary encoder without integral bearing and with optical scanning. Its special properties are its **compact design** with 35 mm outside diameter and only 14 mm height as well as its **easy, self-centering mounting** thanks to a patented slide lock. With its OPTO-ASIC technology, the RENCO R35i offers **the greatest possible functionality with the smallest possible dimensions.**

The **RCML15 rotary encoder** with a height of only **8.9 mm** offers an alternative to the R35i with a very low mounting profile.

Both encoders are available with output signals for controlling motors with block commutation.



This brochure supersedes all previous editions, which thereby become invalid. The basis for ordering from HEIDENHAIN is always the edition of this brochure valid when the contract is made.

Standards (ISO, EN, etc.) apply only where explicitly stated in the brochure.

Contents

Areas of application		
	Servo drive technology	4
	Robotics	4
	Medical technology	4
	Automation	5
	Facility engineering	5
Selection guide		
	R35i	6
	RCML15	8
Specifications		
	R35i rotary encoder with Ø 32.5 mm flange	10
	R35i rotary encoder with Ø 46.0 mm flange	12
	R35i rotary encoder with synchro flange (resolver size 15)	14
	RCML15 rotary encoder	16
Electrical connection		
	General electrical information	18
	LD square-wave signals	20
	PP square-wave signals	22
	Encoder cable	24
Mounting		
	General mechanical information	25
	Mounting the R35i	26
	Mounting the RCML 15	29
	Mounting accessories	33
Diagnostic and testing equipment		
	PWM 20 and ATS	34
	PWM 9	34
	Specific inspection equipment	35

Areas of application

The RENCO R35i is an incremental rotary encoder without integral bearing and with optical scanning. Its special properties are its **compact design** with 35 mm outside diameter and only 14 mm height as well as its **easy, self-centering mounting** thanks to a patented slide lock. With its OPTO-ASIC technology, the RENCO R35i offers the **greatest possible functionality with the smallest possible dimensions**—ideal preconditions for their use in the following areas of application:

Servo drive technology

Thanks to its position acquisition with the high resolution of up to 10000 signals per revolution (40000 measuring steps after four-fold evaluation) and the wide working temperature range of $-30\text{ }^{\circ}\text{C}$ to $+115\text{ }^{\circ}\text{C}$, the RENCO R35i is **ideally suited as feedback system for stepper motors in the Closed Loop mode**. In addition, the RENCO R35i provides three commutation signals U, V, and W, in order to power in the proper direction the rotor windings of **BLDC motors** (brushless DC motors) with up to four pole pairs.

Robotics

Robotics is a strongly expanding sector of industry. Thanks to new developments under the rubric of “soft robotics,” new areas of application are opening up that extend far beyond the classical industrial robots for automation technology. In the future, an increasing number of sensitive (i.e. soft), service robots in immediate interaction with humans will serve to assist in facilitating manual processes in production.

Professional service robots are also increasingly assuming jobs such as,

- cleaning facades or solar panels,
- inspecting pipelines,
- fully automatic harvesting aids in agriculture,
- automatically controlled conveyor or loading vehicles in logistics.

Thanks to its compact design and **outstanding performance data**, the RENCO R35i is the ideal solution for all of these applications. Moreover, it features **low energy consumption during operation** for mobile, battery-powered applications.

Medical technology

Thanks to various features and properties, the RENCO R35i is very well suited for demanding applications in the area of medical technology. Its material mix is **RoHS conformant** and therefore contains no hazardous materials as per EC Directive 2011/65/EU. In addition, its high reliability and **noise-proof data transfer** with line drivers as per EIA standard RS 422 play an important role for high patient safety with physiotherapeutic equipment and high analysis quality and reproducibility in lab applications. The high resolution of up to 10000 signal periods per revolution fulfills the requirement for **smooth, jerk-free and precise control**—which is important both for physiotherapeutic devices for patient comfort as well as in liquid handling applications in a lab. Typical areas of application include physiotherapeutic devices such as movement exercisers and lab automation with centrifuges and pipetting systems for liquid handling.



Servo drive technology



Robotics

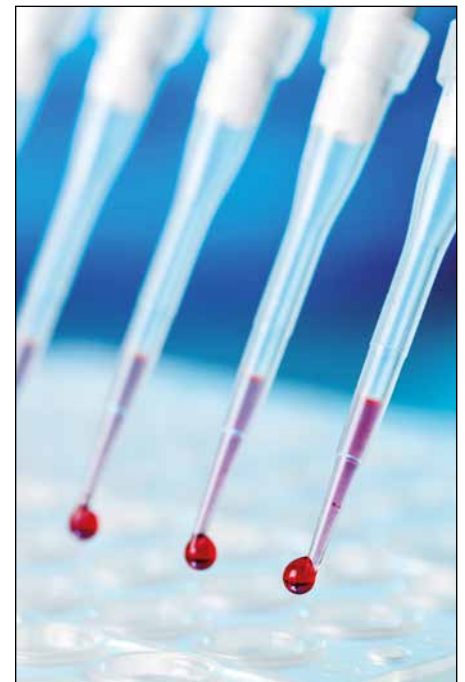

Pipetting

Automation

Automation applications such as in semi-conductor manufacturing or in the food and textile industries are interesting applications for the RENCO R35i. Its strength is the **accurate positioning control** of machines and systems with **high dynamics** at very high signal resolution. Die bonders for chip-on-board manufacturing, automatic coiling machines for the textile industry, palleting systems or automatic coin counters are example applications. The high dynamics of the RENCO R35i result from its short signal processing times and the **high resolution for precise positioning** from its integrated interpolation. The compact design of the R35i resulting from its ASIC technology plays an important role in factory automation, as well.

Facility engineering

Modern residential, administrative and industrial buildings are equipped with a large number of motor-controlled systems. They include for example elevators, ventilation systems or automatic doors and gates. Thanks to its compact dimensions, here the RENCO R35i is also excellently suited for controlling elevator doors or rotational speed in ventilation systems. The providers of facilities technology place great value on **reliability and failure safety**. These properties guarantee comprehensive certification as per ISO quality standards. The serial interface according to EIA standard RS 422 ensures safe and reliable data transfer. It offers **high noise immunity** through its differential, symmetric signal transmission.

A **particularly flat-profile and light alternative** to the R35i available in the RENCO product line is the **RCML15** rotary encoder. It can be used for the same application areas, but thanks to its low profile with a height of only 8.9 mm, it can be used especially in applications with **critical installation conditions and limited space**. In addition to its very flat design, the RENCO RCML15 offers the performance potential of a modern rotary encoder. This includes a resolution of up to 5000 signals per revolution, commutation signals U, V, W and an operating temperature range of $-30\text{ }^{\circ}\text{C}$ to $+100\text{ }^{\circ}\text{C}$. The RCML15 also features a patented slide lock mechanism for simple, self-centering mounting.



Automation



Facility engineering



Application areas with limited installation space

Selection guide for R35i

Order key

R35i-10000/4-6mm-LD/LD-5/0-1-R-C

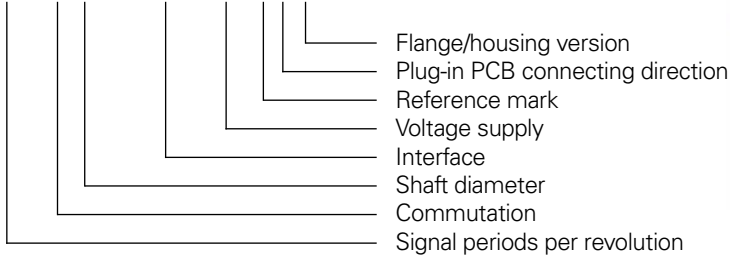

Note: Special versions are identified with an **-S** at the end of the ordering key. These encoders are configured for customer-specific applications, and are to be used only after consultation with your distributor. For special versions, the data in the specific documentation apply, not those in the catalog!

Selection table

Signal periods per revolution	100, 200, 250, 256, 400, 500, 512, 625, 800, 1000, 1024, 1250, 2000, 2048, 2500, 4000, 4096, 5000, 8000, 8192, 10000		
Commutation	0 2, 3, 4	Without commutation Number of commutation signal periods per revolution (= number of pairs of poles)	
Shaft diameter	Metric Inch	4 mm, 5 mm, 6 mm, 8 mm 1/8, 1/8+, 3/16, 3/16+, 1/4, 1/4+, 5/16, 5/16+, 3/8, 3/8+	
Interface	LD PP	Square-wave signals with differential line driver as per RS 422 Square-wave signals with push-pull single-ended driver output	
Voltage supply	5/0	+5 V ±5 %	
Reference mark	1 6 7 8	Width: 90° ±45° elec. Width: 90° ±45° elec. Width: 270° ±45° elec. Width: 270° ±45° elec.	Position: U _{a1} High and U _{a2} High Position: U _{a1} Low and U _{a2} Low Position: U _{a1} High and U _{a2} High Position: U _{a1} Low and U _{a2} Low
PCB connector	R A	Radial Axial	
Flange and housing versions	C, SC* H, SH* C4, SC4* H4, SH4* CR, SCR* HR, SHR*	Flange with Ø 32.5 mm mounting screw circle, closed housing Flange with Ø 32.5 mm mounting screw circle, housing with central hole Flange with Ø 46.0 mm mounting screw circle, closed housing Flange with Ø 46.0 mm mounting screw circle, housing with central hole Synchro flange resolver size15, closed housing Synchro flange resolver size15, housing with central hole	

* Housing with connections for strain relief on encoder cable

Combination possibilities for interface and voltage supply

Without commutation

Interface	Voltage supply
LD/0	5/0
PP/0	5/0

With commutation

Interface	Voltage supply
LD/LD	5/0
LD/PP	5/0
PP/PP	5/0

Packaging unit

The **R35i** rotary encoder is available only in a package size with **10 units**. Rotary encoder housing and mounting material (flange mounting screws and offset screwdriver for shaft fastening) are included in the packaging.

ID number	For ordering key, see <i>Selection cable</i>
788619-xx	<i>Signal periods: 250, 256, 500, 512, 1 000, 1024, 2000, 2048, 4000, 4096, 8000, 8192</i> <i>Flange and housing versions: C, SC, H, SH</i>
764590-xx	<i>Signal periods: 100, 200, 400, 625, 800, 1250, 2500, 5000, 10000</i> <i>Flange and housing versions: C, SC, H, SH</i>
725894-xx	<i>Signal periods: See Selection table</i> <i>Flange and housing versions: C4, SC4, H4, SH4, CR, SCR, HR, SHR</i>

Selection guide for RCML15

Order key

RCML15-2048/3-6mm-5-1

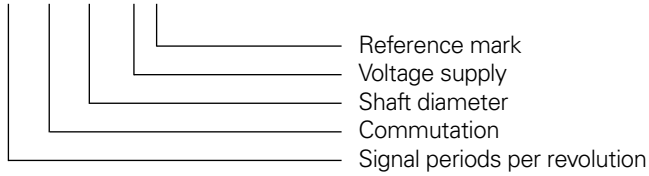

Note: Special versions are identified with an **-S** at the end of the ordering key. These encoders are configured for customer-specific applications. To be used only after consultation with your distributor. *For special versions, the data in the specific documentation apply, not those in the catalog!*

Selection table

Signal periods per revolution	100, 200, 250, 256, 400, 500, 512, 625, 800, 1000, 1024, 1250, 2000, 2048, 2500, 4000, 4096, 5000		
Commutation	0 2, 3, 4	Without commutation Number of commutation signal periods per revolution (= number of pairs of poles)	
Shaft diameter	Metric Inch	5 mm, 6 mm, 8 mm 1/8+, 3/16, 3/16+, 1/4, 1/4+, 5/16, 3/8, 3/8+	
Voltage supply	5	+5V ±5 %	
Reference mark	1 6 7 8	Width: 90° ±45° elec. Width: 90° ±45° elec. Width: 270° ±45° elec. Width: 270° ±45° elec.	Position: U _{a1} High and U _{a2} High Position: U _{a1} Low and U _{a2} Low Position: U _{a1} High and U _{a2} High Position: U _{a1} Low and U _{a2} Low

Packaging unit

The **RCML15** rotary encoder is available only in a package size with **15 units**. The mounting material (flange mounting screws and offset screwdriver for shaft fastening) are included in the packaging.

ID number	For ordering key, see <i>Selection cable</i>
841174-xx	+5 V power supply <i>Signal periods:</i> 250, 256, 500, 512, 1000, 1024, 2000, 2048, 4000, 4096
886065-xx	+5 V power supply <i>Signal periods:</i> 100, 200, 400, 625, 800, 1250, 2500, 5000

R35i rotary encoder

Incremental rotary encoders

- Ø 32.5 mm flange for axial mounting
- Hollow through shaft
- Without integral bearing, self-centering



Housing FOKAA1: H/SH

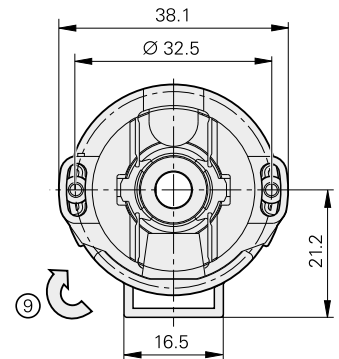
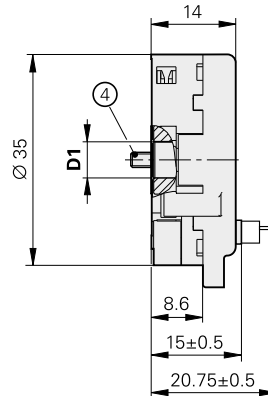
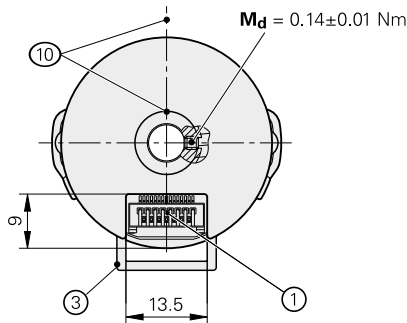

Housing FOKAA1: C/SC

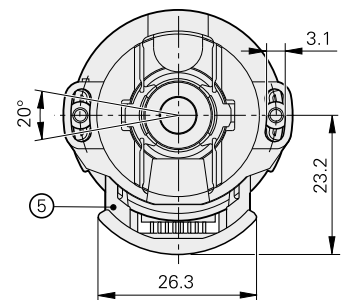
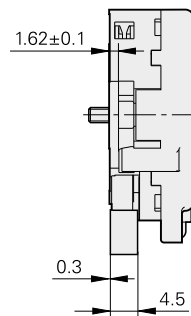
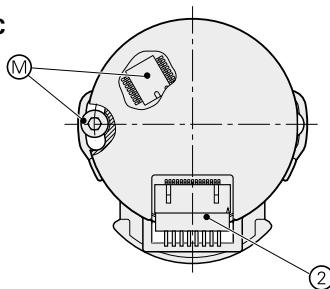

Required mating dimensions

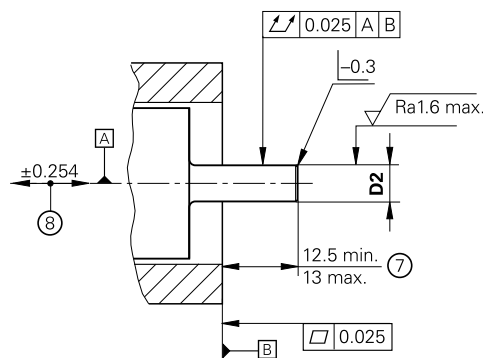
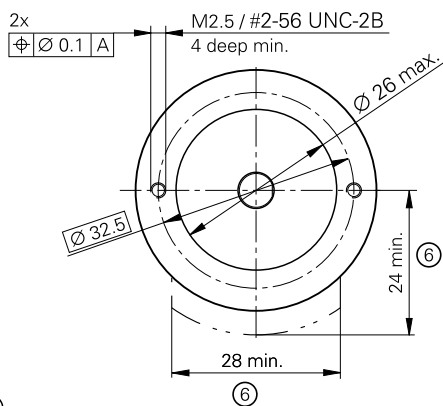

mm

 Tolerancing ISO 8015
 ISO 2768 - m H
 < 6 mm: ±0.2 mm

*) Shaft diameters in inches or mm

WELLA1	*)	D1 $^{+0.01}_{0}$ Ⓔ	D2 $^{0}_{-0.013}$ Ⓔ
0HN	3/8+	Ø 9.528	Ø 9.525
0HM	3/8	Ø 9.520	Ø 9.517
0HB	8 mm	Ø 8	Ø 7.997
0HR	5/16+	Ø 7.940	Ø 7.937
0HP	5/16	Ø 7.932	Ø 7.929
0HF	1/4+	Ø 6.353	Ø 6.350
0HE	1/4	Ø 6.345	Ø 6.342
0HA	6 mm	Ø 6	Ø 5.997
0HC	5 mm	Ø 5	Ø 4.997
0HL	3/16+	Ø 4.765	Ø 4.762
0HK	3/16	Ø 4.757	Ø 4.754
0HD	4 mm	Ø 4	Ø 3.997
0HH	1/8+	Ø 3.178	Ø 3.175
0HG	1/8	Ø 3.170	Ø 3.167

- ☐ = Bearing of mating shaft
- M = Measuring point for operating temperature
- 1 = 15-pin axial plug connector
- 2 = 15-pin radial plug connector
- 3 = Strain relief FOKAA1: SC/SH
- 4 = Torx T8 for flange:
 2x M2.5x5.25 ID 548595-02 oder 2x #2-56 UNCx5.25 ID 548595-03,
 tightening torque 0.21 ± 0.02 Nm
- 5 = Slide lock in mounting position
- 6 = Required installation space for sliding-bolt mechanism
- 7 = Max. dimension for FOKAA1: C/SC
- 8 = Compensation of mounting tolerances and thermal expansion
- 9 = Direction of shaft rotation for output signals as per the interface description
- 10 = Reference mark position ±10°

	R35i				
Interface*	LD/0	PP/0	LD/LD	LD/PP	PP/PP
Signal periods/rev* ¹⁾	100, 200, 250, 256, 400, 500, 512, 625, 800, 1000, 1024, 1250, 2000, 2048, 2500, 4000, 4096, 5000, 8000, 8192, 10000 <i>Metal graduation: up to 5000, glass graduation: over 5000</i>				
Reference mark Width/position*	One 1 <i>Width: 90° ±45° elec. Position: U_{a1} High and U_{a2} High</i> 6 <i>Width: 90° ±45° elec. Position: U_{a1} Low and U_{a2} Low</i> 7 <i>Width: 270° ±45° elec. Position: U_{a1} High and U_{a2} High</i> 8 <i>Width: 270° ±45° elec. Position: U_{a1} Low and U_{a2} Low</i>				
Scanning frequency ²⁾	≤ 200 kHz				
Output frequency	≤ 500 kHz				
Commutation Signal periods*/rev	Without 0		Signal tracks U, V, W 2, 3, 4 (others upon request)		
Electrical connection Connection direction*	PCB connector, 15-pin R = radial, A = axial				
Voltage supply	DC 5 V ± 0.5 V				
Current requirement Typical 5 V, without load Max. 5.5 V, without load Max. 5.5 V, with load	≤ 40 mA ≤ 65 mA ≤ 165 mA	≤ 40 mA ≤ 55 mA ≤ 65 mA	≤ 40 mA ≤ 70 mA ≤ 270 mA	≤ 40 mA ≤ 65 mA ≤ 170 mA	≤ 40 mA ≤ 55 mA ≤ 75 mA
Shaft*	Hollow through shaft with radial fastening <i>Shaft diameter: See Mating dimensions</i>				
Mech. permiss. speed n	<i>Metal graduation: ≤ 30000 rpm</i> <i>Glass graduation: ≤ 12000 rpm</i>				
Moment of inertia of rotor	<i>Metal graduation: 0.2 x 10⁻⁶ kgm²</i> <i>Glass graduation: 0.3 x 10⁻⁶ kgm²</i>				
Permissible motion of measured shaft	<i>Axial: ±0.254 mm</i> <i>Radial runout: 0.025 mm TIR</i>				
Vibration 55 Hz to 2000 Hz Shock 6 ms	≤ 200 m/s ² (EN 60068-2-6) ≤ 1000 m/s ² (EN 60068-2-27)				
Operating temperature	-30 °C to 115 °C				
Relative humidity	≤ 93 % (40 °C/21 d as per EN 60068-2-78); without condensation				
Protection EN 60529	IP 30 ³⁾				
Mass	≈ 0.03 kg				

* Please select when ordering

¹⁾ The number of signal periods at the output results from the base graduation and a permanently set interpolation (none, 2-fold, 4-fold, 8-fold).
Available base graduations: *Metal: 100, 250, 256, 500, 512, 625*
Glass: 1000, 1024, 1250

²⁾ The electrically permissible rotational speed is determined by the base graduation used. It may exceed neither scanning frequency, nor the maximum output frequency, nor the mechanically permissible speed.

³⁾ CE compliance of the complete system must be ensured by taking the correct measures during installation.

R35i rotary encoder

Incremental rotary encoders

- Ø 46.03 mm flange for axial mounting
- Hollow through shaft
- Without integral bearing, self-centering



Housing FOKAA1: H4/SH4

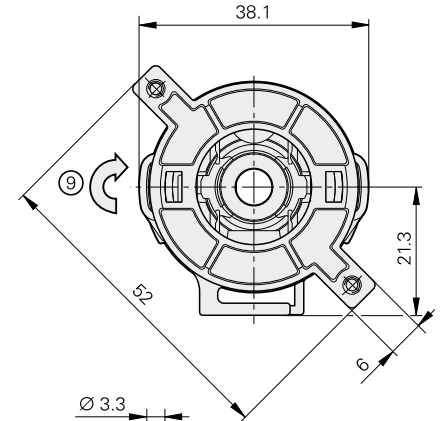
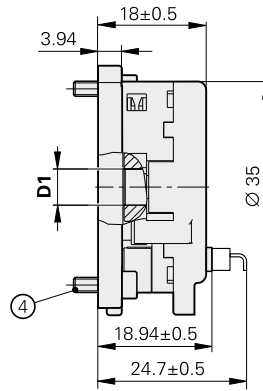
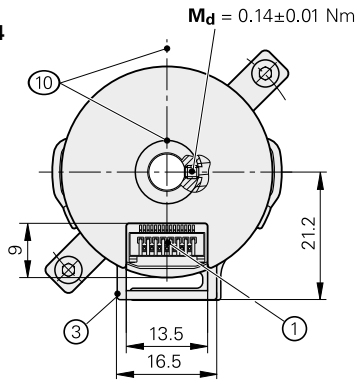

Housing FOKAA1: C4/SC4

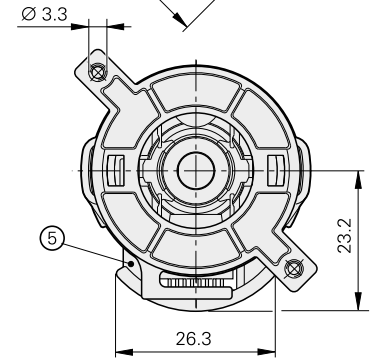
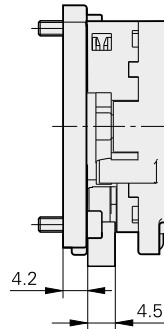
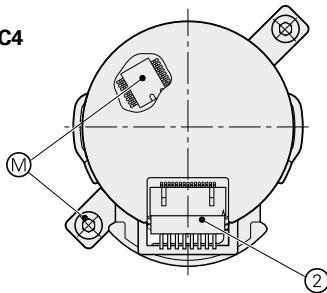

Required mating dimensions

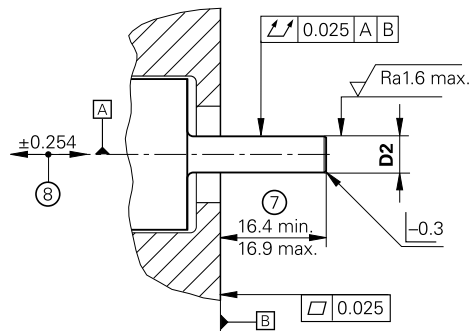
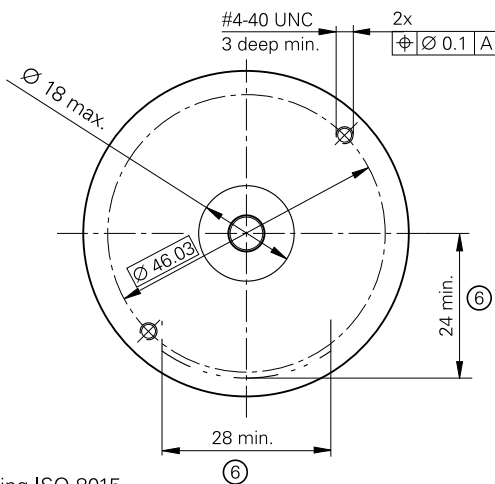

mm
Tolerancing ISO 8015
ISO 2768 - m H
< 6 mm: ±0.2 mm

*) Shaft diameters in inches or mm

WELLA1	*)	D1 +0.01 0	D2 0 -0.013
0HN	3/8+	Ø 9.528	Ø 9.525
0HM	3/8	Ø 9.520	Ø 9.517
0HB	8 mm	Ø 8	Ø 7.997
0HR	5/16+	Ø 7.940	Ø 7.937
0HP	5/16	Ø 7.932	Ø 7.929
0HF	1/4+	Ø 6.353	Ø 6.350
0HE	1/4	Ø 6.345	Ø 6.342
0HA	6 mm	Ø 6	Ø 5.997
0HC	5 mm	Ø 5	Ø 4.997
0HL	3/16+	Ø 4.765	Ø 4.762
0HK	3/16	Ø 4.757	Ø 4.754
0HD	4 mm	Ø 4	Ø 3.997
0HH	1/8+	Ø 3.178	Ø 3.175
0HG	1/8	Ø 3.170	Ø 3.167

- ⊠ = Bearing of mating shaft
- M = Measuring point for operating temperature
- 1 = 15-pin axial plug connector
- 2 = 15-pin radial plug connector
- 3 = Strain relief FOKAA1: SC4/SH4
- 4 = Mounting screws, width A/F 3/32" for flange:
2x #4-40 UNCx6.35 ID 200507-A0, tightening torque 0.21±0.02 Nm
- 5 = Slide lock in mounting position
- 6 = Required installation space for sliding-bolt mechanism
- 7 = Max. dimension for FOKAA1: C4/SC4
- 8 = Compensation of mounting tolerances and thermal expansion
- 9 = Direction of shaft rotation for output signals as per the interface description
- 10 = Reference mark position ±10°

	R35i				
Interface*	LD/0	PP/0	LD/LD	LD/PP	PP/PP
Signal periods/rev* ¹⁾	100, 200, 250, 256, 400, 500, 512, 625, 800, 1000, 1024, 1250, 2000, 2048, 2500, 4000, 4096, 5000, 8000, 8192, 10000 <i>Metal graduation: up to 5000, glass graduation: over 5000</i>				
Reference mark Width/position*	One 1 <i>Width: 90° ±45° elec. Position: U_{a1} High and U_{a2} High</i> 6 <i>Width: 90° ±45° elec. Position: U_{a1} Low and U_{a2} Low</i> 7 <i>Width: 270° ±45° elec. Position: U_{a1} High and U_{a2} High</i> 8 <i>Width: 270° ±45° elec. Position: U_{a1} Low and U_{a2} Low</i>				
Scanning frequency ²⁾	≤ 200 kHz				
Output frequency	≤ 500 kHz				
Commutation Signal periods*/rev	Without 0		Signal tracks U, V, W 2, 3, 4 (others upon request)		
Electrical connection Connection direction*	PCB connector, 15-pin R = radial, A = axial				
Voltage supply	DC 5 V ± 0.5 V				
Current requirement Typical 5 V, without load Max. 5.5 V, without load Max. 5.5 V, with load	≤ 40 mA ≤ 65 mA ≤ 165 mA	≤ 40 mA ≤ 55 mA ≤ 65 mA	≤ 40 mA ≤ 70 mA ≤ 270 mA	≤ 40 mA ≤ 65 mA ≤ 170 mA	≤ 40 mA ≤ 55 mA ≤ 75 mA
Shaft*	Hollow through shaft with radial fastening <i>Shaft diameter: See Mating dimensions</i>				
Mech. permiss. speed n	<i>Metal graduation: ≤ 30000 rpm</i> <i>Glass graduation: ≤ 12000 rpm</i>				
Moment of inertia of rotor	<i>Metal graduation: 0.2 x 10⁻⁶ kgm²</i> <i>Glass graduation: 0.3 x 10⁻⁶ kgm²</i>				
Permissible motion of measured shaft	<i>Axial: ±0.254 mm</i> <i>Radial runout: 0.025 mm TIR</i>				
Vibration 55 Hz to 2000 Hz Shock 6 ms	≤ 200 m/s ² (EN 60068-2-6) ≤ 1000 m/s ² (EN 60068-2-27)				
Operating temperature	-30 °C to 115 °C				
Relative humidity	≤ 93 % (40 °C/21 d as per EN 60068-2-78); without condensation				
Protection EN 60529	IP 30 ³⁾				
Mass	≈ 0.03 kg				

* Please select when ordering

¹⁾ The number of signal periods at the output results from the base graduation and a permanently set interpolation (none, 2-fold, 4-fold, 8-fold).
Available base graduations: *Metal*: 100, 250, 256, 500, 512, 625
Glass: 1000, 1024, 1250

²⁾ The electrically permissible rotational speed is determined by the base graduation used. It may exceed neither scanning frequency, nor the maximum output frequency, nor the mechanically permissible speed.

³⁾ CE compliance of the complete system must be ensured by taking the correct measures during installation.

R35i rotary encoder

Incremental rotary encoders

- Synchro flange (resolver size 15)
- Hollow through shaft
- Without integral bearing, self-centering



Housing FOKAA1: HR/SHR

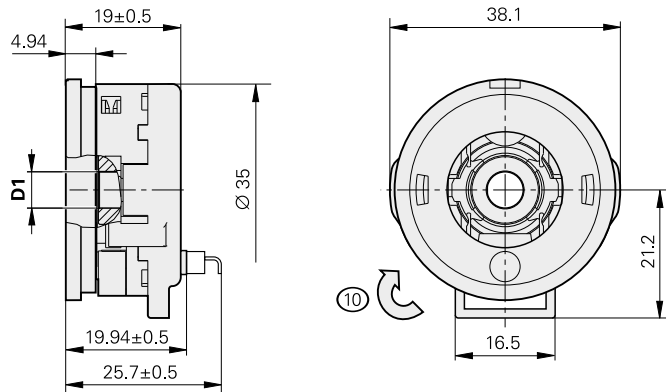
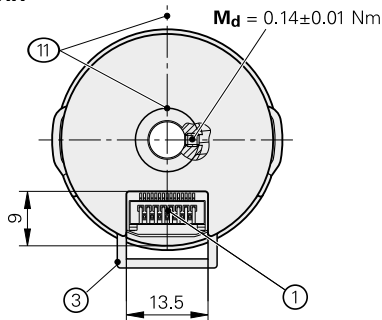

Housing FOKAA1: CR/SCR

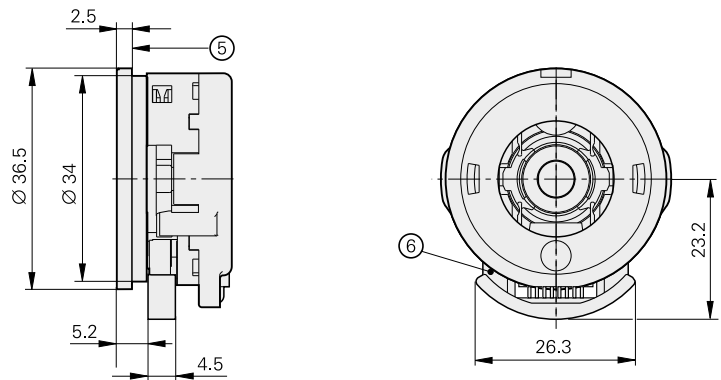
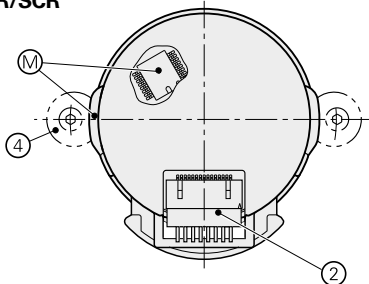

Required mating dimensions

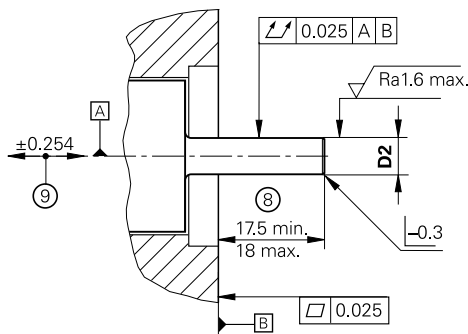
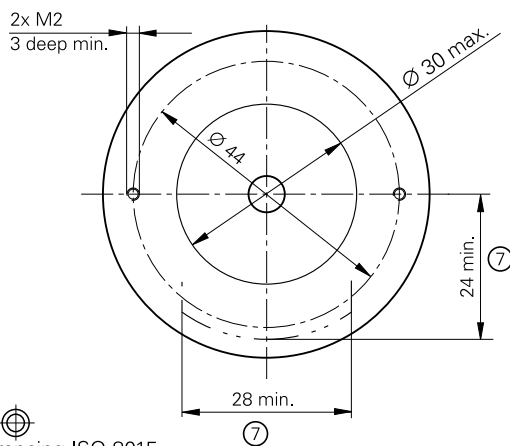

mm
Tolerancing ISO 8015
ISO 2768 - m H
< 6 mm: ±0.2 mm

- ☐ = Bearing of mating shaft
- M = Measuring point for operating temperature
- 1 = 15-pin axial plug-in PCB
- 2 = 15-pin radial plug-in PCB
- 3 = Strain relief FOKAA1: SCR/SHR
- 4 = Proposed fastening with fixing clamp, ID 200032-02, and screw, ISO 4762 – M2, 2x 180° or 3x 120°; tightening torque 0.21 ± 0.03 Nm
- 5 = Clamping surface
- 6 = Slide lock in mounting position
- 7 = Required installation space for sliding-bolt mechanism
- 8 = Max. dimension for FOKAA1: CR/SCR
- 9 = Compensation of mounting tolerances and thermal expansion
- 10 = Direction of shaft rotation for output signals as per the interface description
- 11 = Reference mark position ±10°

*) Shaft diameters in inches or mm

WELLA1	*)	D1 +0.01 0 E	D2 0 -0.013 E
0HN	3/8+	Ø 9.528	Ø 9.525
0HM	3/8	Ø 9.520	Ø 9.517
0HB	8 mm	Ø 8	Ø 7.997
0HR	5/16+	Ø 7.940	Ø 7.937
0HP	5/16	Ø 7.932	Ø 7.929
0HF	1/4+	Ø 6.353	Ø 6.350
0HE	1/4	Ø 6.345	Ø 6.342
0HA	6 mm	Ø 6	Ø 5.997
0HC	5 mm	Ø 5	Ø 4.997
0HL	3/16+	Ø 4.765	Ø 4.762
0HK	3/16	Ø 4.757	Ø 4.754
0HD	4 mm	Ø 4	Ø 3.997
0HH	1/8+	Ø 3.178	Ø 3.175
0HG	1/8	Ø 3.170	Ø 3.167

	R35i				
Interface*	LD/0	PP/0	LD/LD	LD/PP	PP/PP
Signal periods/rev* ¹⁾	100, 200, 250, 256, 400, 500, 512, 625, 800, 1000, 1024, 1250, 2000, 2048, 2500, 4000, 4096, 5000, 8000, 8192, 10000 <i>Metal graduation: up to 5000, glass graduation: over 5000</i>				
Reference mark Width/position*	One 1 <i>Width: 90° ±45° elec. Position: U_{a1} High and U_{a2} High</i> 6 <i>Width: 90° ±45° elec. Position: U_{a1} Low and U_{a2} Low</i> 7 <i>Width: 270° ±45° elec. Position: U_{a1} High and U_{a2} High</i> 8 <i>Width: 270° ±45° elec. Position: U_{a1} Low and U_{a2} Low</i>				
Scanning frequency ²⁾	≤ 200 kHz				
Output frequency	≤ 500 kHz				
Commutation Signal periods*/rev	Without 0		Signal tracks U, V, W 2, 3, 4 (others upon request)		
Electrical connection Connection direction*	PCB connector, 15-pin R = radial, A = axial				
Voltage supply	DC 5 V ± 0.5 V				
Current requirement Typical 5 V, without load Max. 5.5 V, without load Max. 5.5 V, with load	≤ 40 mA ≤ 65 mA ≤ 165 mA	≤ 40 mA ≤ 55 mA ≤ 65 mA	≤ 40 mA ≤ 70 mA ≤ 270 mA	≤ 40 mA ≤ 65 mA ≤ 170 mA	≤ 40 mA ≤ 55 mA ≤ 75 mA
Shaft*	Hollow through shaft with radial fastening <i>Shaft diameter: See Mating dimensions</i>				
Mech. permiss. speed n	<i>Metal graduation: ≤ 30000 rpm</i> <i>Glass graduation: ≤ 12000 rpm</i>				
Moment of inertia of rotor	<i>Metal graduation: 0.2 x 10⁻⁶ kgm²</i> <i>Glass graduation: 0.3 x 10⁻⁶ kgm²</i>				
Permissible motion of measured shaft	<i>Axial: ±0.254 mm</i> <i>Radial runout: 0.025 mm TIR</i>				
Vibration 55 Hz to 2000 Hz Shock 6 ms	≤ 200 m/s ² (EN 60068-2-6) ≤ 1000 m/s ² (EN 60068-2-27)				
Operating temperature	-30 °C to 115 °C				
Relative humidity	≤ 93 % (40 °C/21 d as per EN 60068-2-78); without condensation				
Protection EN 60529	IP 30 ³⁾				
Mass	≈ 0.03 kg				

* Please select when ordering

¹⁾ The number of signal periods at the output results from the base graduation and a permanently set interpolation (none, 2-fold, 4-fold, 8-fold).
Available base graduations: *Metal: 100, 250, 256, 500, 512, 625*
Glass: 1000, 1024, 1250

²⁾ The electrically permissible rotational speed is determined by the base graduation used. It may exceed neither scanning frequency, nor the maximum output frequency, nor the mechanically permissible speed.

³⁾ CE compliance of the complete system must be ensured by taking the correct measures during installation.

RCML15 rotary encoder

Incremental rotary encoder

- Ø 32.5 mm flange for axial mounting
- Hollow through shaft
- Without integral bearing, self-centering

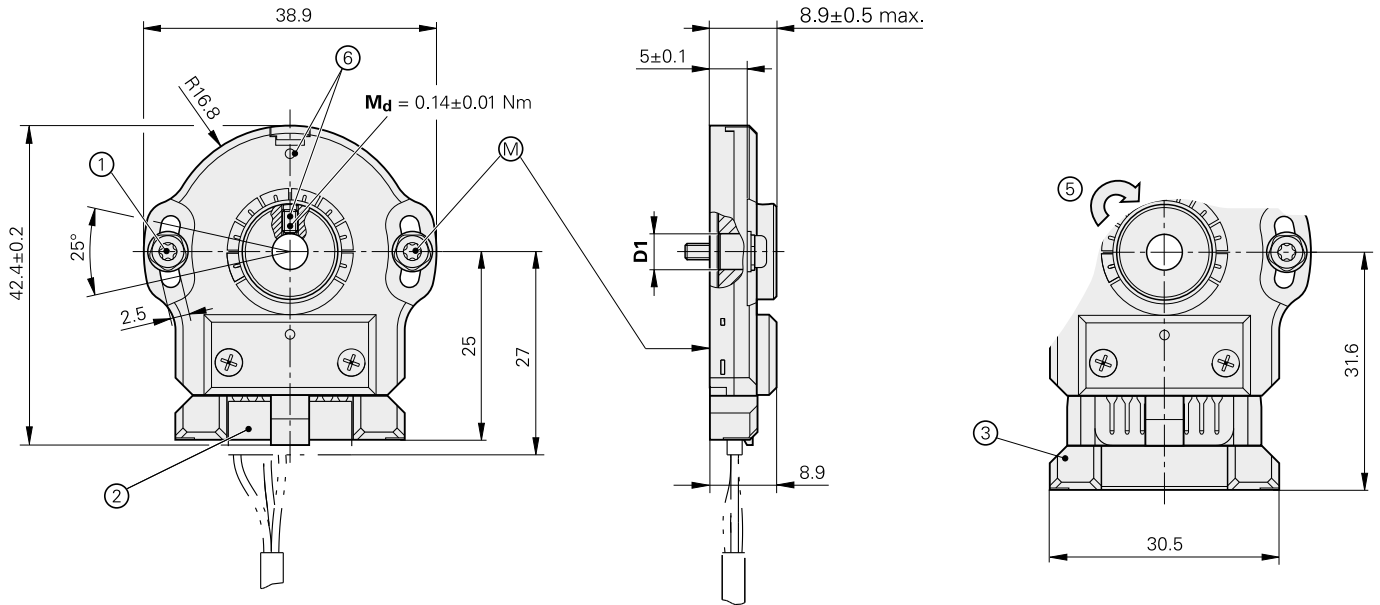

Required mating dimensions

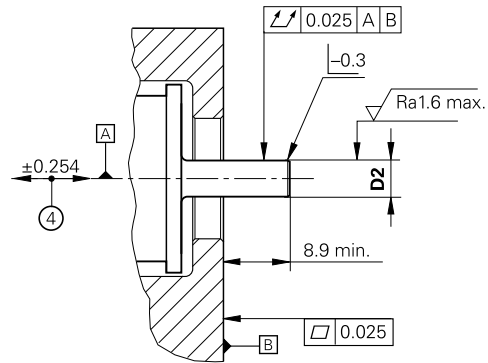
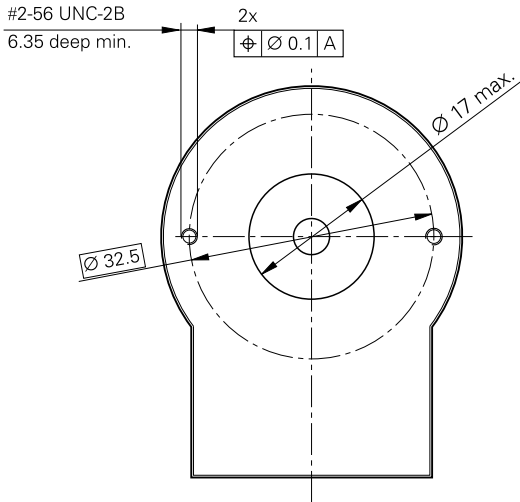

mm

Tolerancing ISO 8015
ISO 2768 - m H
< 6 mm: ±0.2 mm

* Shaft diameters in inches or mm

- ▣ = Bearing of mating shaft
- M = Measuring point for operating temperature
- 1 = Torx T8 mounting screws for flange:
2x #2-56 UNCx9.25 ID 548595-01, tightening torque 0.21±0.02 Nm
- 2 = PCB connector
- 3 = Slide lock in mounting position
- 4 = Compensation of mounting tolerances and thermal expansion
- 5 = Direction of shaft rotation for output signals as per the interface description
- 6 = Reference mark position ±10°

WELLA1	*)	D1 +0.01 0	D2 0 -0.013
0HN	3/8+	Ø 9.528	Ø 9.525
0HM	3/8	Ø 9.520	Ø 9.517
0HB	8 mm	Ø 8	Ø 7.997
0HP	5/16	Ø 7.932	Ø 7.929
0HF	1/4+	Ø 6.353	Ø 6.350
0HE	1/4	Ø 6.345	Ø 6.342
0HA	6 mm	Ø 6	Ø 5.997
0HC	5 mm	Ø 5	Ø 4.997
0HL	3/16+	Ø 4.765	Ø 4.762
0HK	3/16	Ø 4.757	Ø 4.754
0HD	4 mm	Ø 4	Ø 3.997
0HH	1/8+	Ø 3.178	Ø 3.175

RCML15	
Interface*	PP/0 PP/PP
Signal periods/rev* ¹⁾	100, 200, 250, 256, 400, 500, 512, 625, 800, 1000, 1024, 1250, 2000, 2048, 2500, 4000, 4096, 5000
Reference mark Width/position*	One 1 <i>Width: 90° ±45° elec. Position: U_{a1} High and U_{a2} High</i> 6 <i>Width: 90° ±45° elec. Position: U_{a1} Low and U_{a2} Low</i> 7 <i>Width: 270° ±45° elec. Position: U_{a1} High and U_{a2} High</i> 8 <i>Width: 270° ±45° elec. Position: U_{a1} Low and U_{a2} Low</i>
Scanning frequency ²⁾	≤ 200 kHz
Output frequency	≤ 500 kHz
Commutation Signal periods*/rev	Without 0 Signal tracks U, V, W 2, 3, 4 (others upon request)
Electrical connection	PCB connector, 8-pin
Voltage supply*	DC 5V ± 0.5V
Current requirement Typical 5V, without load Max. 5.5V, without load Max. 5.5V, with load	≤ 40 mA ≤ 55 mA ≤ 65 mA ≤ 40 mA ≤ 55 mA ≤ 75 mA
Shaft*	Hollow through shaft with radial fastening <i>Shaft diameter: See Mating dimensions</i>
Mech. permiss. speed n	≤ 30000 rpm
Moment of inertia of rotor	0.9 × 10 ⁻⁶ kgm ²
Permissible motion of measured shaft	<i>Axial: ±0.254 mm</i> <i>Radial runout: 0.025 mm TIR</i>
Vibration 55 Hz to 2000 Hz Shock 6 ms	≤ 200 m/s ² (EN 60068-2-6) ≤ 1000 m/s ² (EN 60068-2-27)
Operating temperature	-30 °C to 100 °C
Relative humidity	≤ 93 % (40 °C/21 d as per EN 60068-2-78); without condensation
Protection EN 60529	IP 40 ³⁾
Mass	≈ 0.02 kg

* Please select when ordering

¹⁾ The number of signal periods at the output results from the base graduation and a permanently set interpolation (none, 2-fold, 4-fold, 8-fold).
Available base gradings: 100, 250, 256, 500, 512, 625

²⁾ The electrically permissible rotational speed is determined by the base graduation used. It may exceed neither scanning frequency, nor the maximum output frequency, nor the mechanically permissible speed.

³⁾ CE compliance of the complete system must be ensured by taking the correct measures during installation.

General electrical information

No fault identification measures have been implemented in RENCO products. The operational safety of the application in connection with the encoders is to be ensured in the total system.

Voltage supply

Connect the encoders only to subsequent electronics whose power supply is generated from PELV systems (EN 50178). The R35i and RCML15 rotary encoders fulfill the requirements of standard IEC 61010-1 only if the voltage is supplied from a secondary circuit with current limitation as per IEC 61010-1^{3rd Ed.}, Section 9.4 or with power limitation as per IEC 60950-1^{2nd Ed.}, Section 2.5 or from a Class 2 secondary circuit as specified in UL1310.¹⁾

The encoders require a stabilized DC voltage supply U_P . The required voltage supply and the current consumption are given in the respective *Specifications*.

The permissible ripple content of the DC voltage is:

- High frequency interference
 $U_{PP} < 250 \text{ mV}$ with $dU/dt > 5 \text{ V}/\mu\text{s}$
- Low frequency fundamental ripple
 $U_{PP} < 100 \text{ mV}$

However, the limits of the supply voltage must not be violated by the ripple content.

The voltage values must be complied with at the encoder, i.e., without cable influences. The voltage drop ΔU in the supply lines is calculated as follows:

$$\Delta U = 2 \cdot \frac{1.05 \cdot L_C}{56 \cdot A_P} \cdot I_M \cdot 10^{-3}$$

Where:

ΔU	Line voltage drop in V
L_C	Cable length in m
A_P	Cross section of supply lines in mm^2
I_M	Current consumption in mA
2	Outgoing and incoming lines
1.05	Length factor due to twisted wires
56	Electrical conductivity of copper

If the value for the voltage drop is known, the parameters of voltage at the encoder, current consumption, as well as power consumption of the encoder and the power provided by the subsequent electronics can be calculated for the encoder and subsequent electronics.

Transient response of supply voltage and switch-on behavior

The output signals are invalid outside of the permissible supply voltage range at the encoder (see *Specifications*).

Electrically permissible speed

The maximum permissible speed of an encoder is derived from

- the mechanically permissible speed (see *Specifications*) and
 - the electrically permissible shaft speed.
- The electrically permissible speed is limited by the maximum permissible scanning frequency and the maximum permissible output frequency (see *Specifications*).

Block commutation

Number of signal periods $\hat{=}$ pole pairs
1 pole pair $\hat{=}$ 2 motor poles

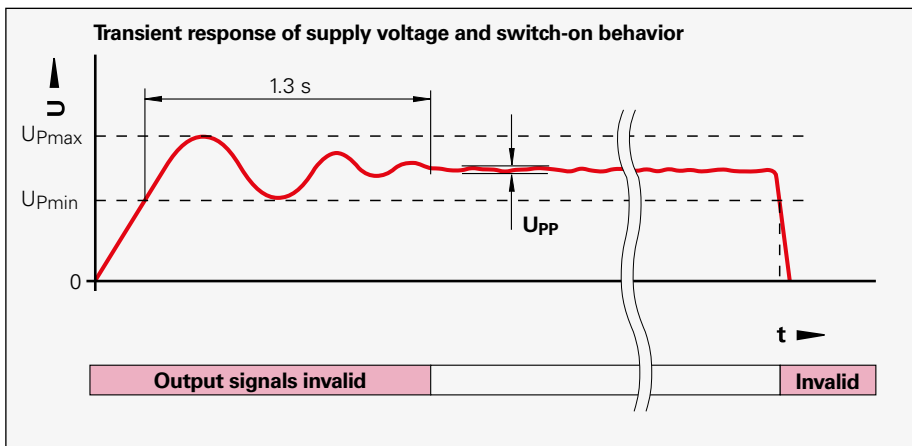

¹⁾ Instead of IEC 61010-1^{3rd Ed.}, Section 9.4, the corresponding sections of DIN EN 61010-1, EN 61010-1, UL 61010-1 and CAN/CSA-C22.2 No. 61010-1 can also be used, and instead of IEC 60950-1^{2nd Ed.}, Section 2.5, the corresponding sections of DIN EN 60950-1, EN 60950-1, UL 60950-1, CAN/CSA-C22.2 No. 60950-1 can also be used.

Electromagnetic compatibility (EMC)

CE compliance of the complete system must be ensured by taking the correct measures during installation, e.g. through the use of suitable shielding measures (conductive housing, shield connection of encoder cable, etc.).

Sources of electrical interference

Electrical interference is caused mainly through capacitive or inductive transfer. Inductive transfer can be introduced into the system over signal lines and input or output terminals. Typical sources of electrical interference include:

- Strong magnetic fields from transformers, brakes and electric motors
- Relays, contactors and solenoid valves
- High-frequency equipment, pulse devices, and stray magnetic fields from switch-mode power supplies
- AC power lines and supply lines to the above devices

Measures

The following measures must be complied with for disturbance-free operation. If other actions are taken, specific measures regarding electrical safety and EMC are required.

- Consider the voltage drop in the supply wires.
 - Use connecting elements (such as connectors or terminal boxes) with metal housings. Only the signals and power supply of the connected encoder may be routed through these elements.
 - Connect the conductive housing of the encoder, connecting elements and subsequent electronics through the shield of the cable. Ensure that the shield has complete contact over the entire surface (360°).
 - Connect the shield to functional ground as per the mounting instructions.
 - Prevent contact of the shield (e.g. connector housing) with other metal surfaces. Pay attention to this when installing cables.
- Do not install signal cables in the direct vicinity of interference sources (inductive consumers such as contactors, motors, frequency inverters, solenoids, etc.).
 - Sufficient decoupling from interference-signal-conducting cables can usually be achieved by an air clearance of 100 mm or, when cables are in metal ducts, by a grounded partition.
 - A minimum spacing of 200 mm to inductors in switch-mode power supplies is required.
 - If compensating currents are to be expected within the overall system, a separate equipotential bonding conductor must be provided. The shield does not have the function of an equipotential bonding conductor.
 - Provide power only from PELV systems (see EN 50 178 for an explanation of the term) to position encoders, and provide high-frequency grounding with low impedance (see EN 60204-1 Chapter EMC).

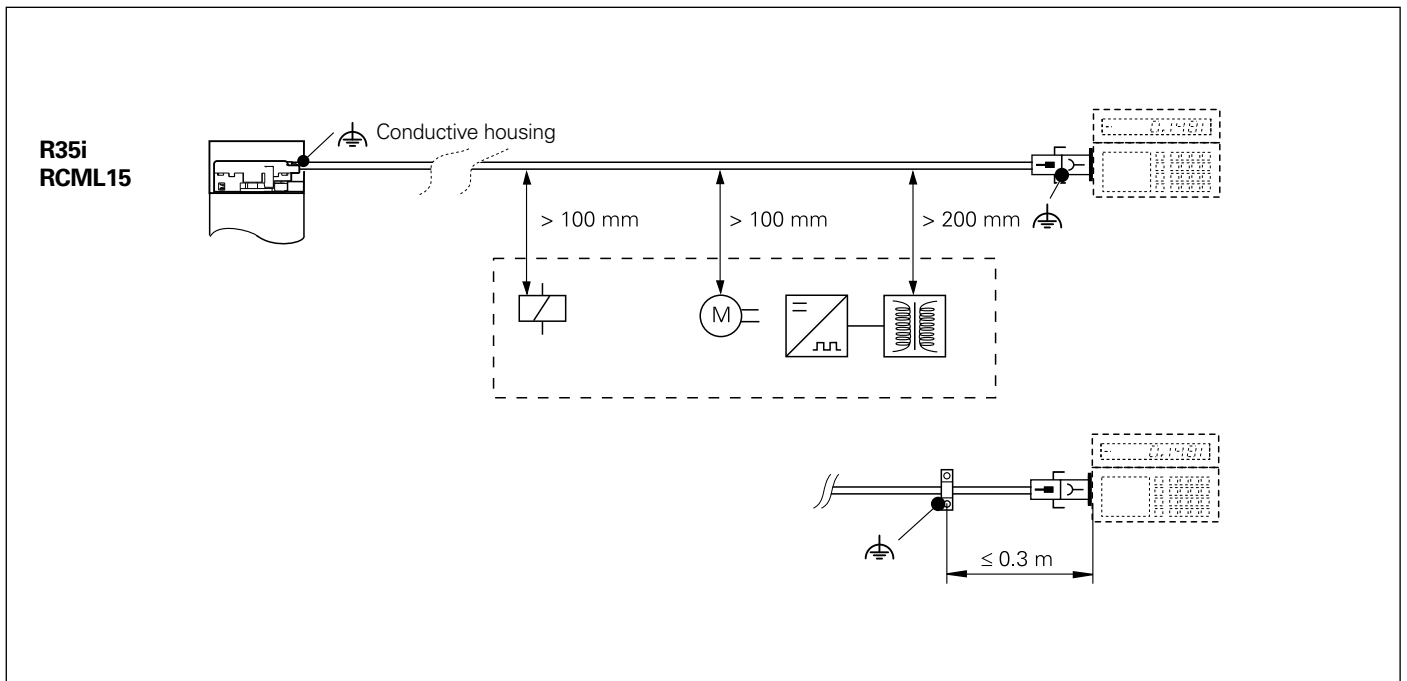

LD square-wave signals

For incremental and commutation signals with differential line driver as per EIA standard RS 422.

Incremental signals	Two square-wave signals U_{a1} , U_{a2} with 90° elec. phase shift and their inverted signals $\overline{U_{a1}}$, $\overline{U_{a2}}$
Reference mark signal Pulse width	One square-wave pulse U_{a0} and its inverted pulse $\overline{U_{a0}}$ 90° elec. or 270° elec. <i>For ordering key, see the Selection Guide or the Specifications</i>
Commutation signals	Three square-wave signals U , V , W and their inverse signals \overline{U} , \overline{V} , \overline{W}
Signal amplitude	Differential line driver as per EIA standard RS-422
Permissible load	$Z_0 \geq 100 \Omega$ Between associated outputs $ I_L \leq 20 \text{ mA}$ Maximum load per output $C_{load} \leq 1000 \text{ pF}$ With respect to 0 V Outputs protected against short circuit to 0 V
Switching times (10% to 90%)	$t_r / t_f \leq 30 \text{ ns}$ (typically 10 ns) with 1 m cable and recommended input circuitry

U_{a1} , $\overline{U_{a1}}$
 U_{a2} , $\overline{U_{a2}}$

On-off ratio

$X1+X2 = 0.5T \pm 0.2T$
 $X2+X3 = 0.5T \pm 0.2T$

Phase angle

$0.375T \geq Xn \geq 0.125T$
($n = 1, 2, 3, 4$)

U_{a0} , $\overline{U_{a0}}$

Pulse width/position

1: $TM = 0.25T \pm 0.125T$

6: $TM = 0.25T \pm 0.125T$

7: $TM = 0.75T \pm 0.125T$

8: $TM = 0.75T \pm 0.125T$

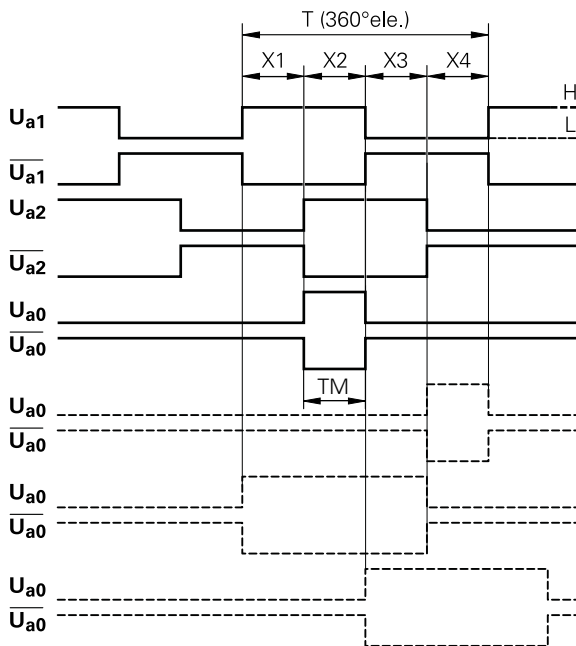

U , \overline{U} , V , \overline{V} ,
 W , \overline{W}

On-off ratio

$Rm = (360^\circ \text{ mech.} / \text{number of signal periods}) \pm 2^\circ \text{ mech.}$

Phase angle

$Yn = Rm / 6 \pm 2^\circ \text{ mech.}$

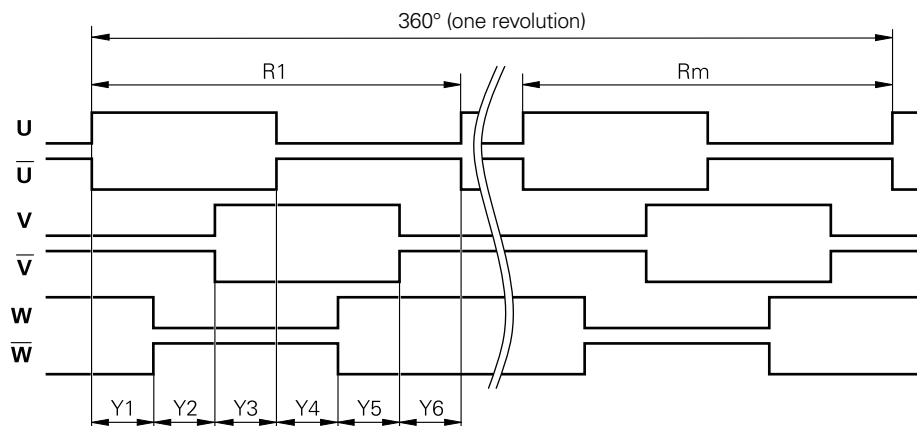

Input circuitry of subsequent electronics

For incremental, reference-mark and commutation signals

Dimensioning

IC₁ = Recommended differential line receiver DS 26 C 32 AT

Z₀ = 120 Ω

C₁ = 220 pF (serves to improve noise immunity)

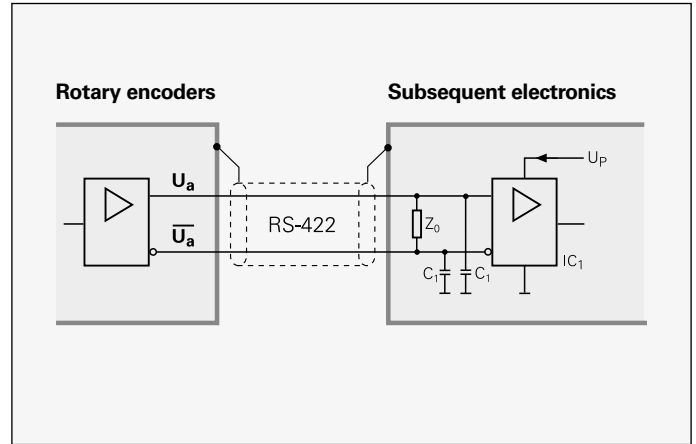

R35i pin layout

15-pin PCB connector															
	Voltage supply		Incremental signals				Reference mark signal		Commutation signals						
15	13	14	1	2	3	4	5	6	7	8	9	10	11	12	
LD/0	U _P	0V	U _{a1}	\overline{U}_{a1}	U _{a2}	\overline{U}_{a2}	U _{a0}	\overline{U}_{a0}	-	-	-	-	-	-	
LD/LD	U _P	0V	U _{a1}	\overline{U}_{a1}	U _{a2}	\overline{U}_{a2}	U _{a0}	\overline{U}_{a0}	U	\overline{U}	V	\overline{V}	W	\overline{W}	
LD/PP	U _P	0V	U _{a1}	\overline{U}_{a1}	U _{a2}	\overline{U}_{a2}	U _{a0}	\overline{U}_{a0}	U	-	V	-	W	-	

Vacant pins must not be used!

PP square-wave signals

For incremental and commutation signals with single-ended push/pull driver output.

Incremental signals	Two square-wave signals U_{a1} , U_{a2} with 90° elec. phase shift
Reference mark signal Pulse width	One square-wave pulse U_{a0} 90° elec. or 270° elec. <i>For ordering key, see the Selection Guide or the Specifications</i>
Commutation signals	3 square-wave signals U, V, W
Signal amplitude	<i>Voltage supply +5 V:</i> $U_H > 2.5\text{ V}$ at $-I_H = 4\text{ mA}$ $U_L < 0.5\text{ V}$ at $I_L = 4\text{ mA}$
Permissible load	$ I \leq 4\text{ mA}$ maximum load per output Outputs are not short-circuit proof
Switching times (10 % to 90 %)	$t_r / t_f \leq 30\text{ ns}$ With indicated input circuit (without cable)

U_{a1} , U_{a2}

On-off ratio

$X1 + X2 = 0.5T \pm 0.2T$

$X2 + X3 = 0.5T \pm 0.2T$

Phase angle

$0.375T \geq X_n \geq 0.125T$

($n = 1, 2, 3, 4$)

U_{a0}

Pulse width/position

1: $TM = 0.25T \pm 0.125T$

6: $TM = 0.25T \pm 0.125T$

7: $TM = 0.75T \pm 0.125T$

8: $TM = 0.75T \pm 0.125T$

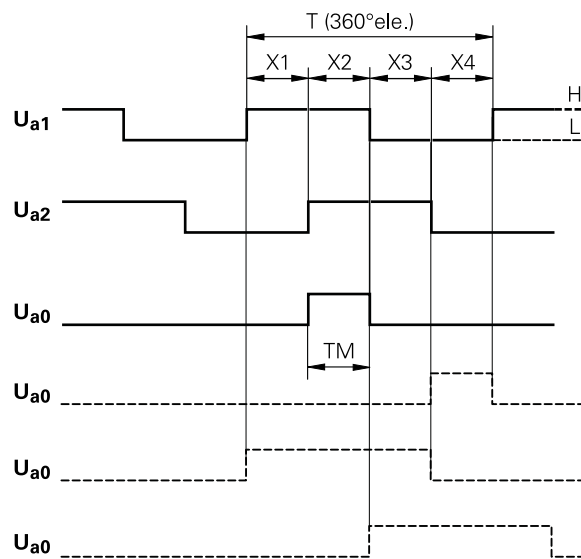

U, V, W

On-off ratio

$R_m = (360^\circ \text{ mech.} / \text{number of signal periods}) \pm 2^\circ \text{ mech.}$

Phase angle

$Y_n = R_m / 6 \pm 2^\circ \text{ mech.}$

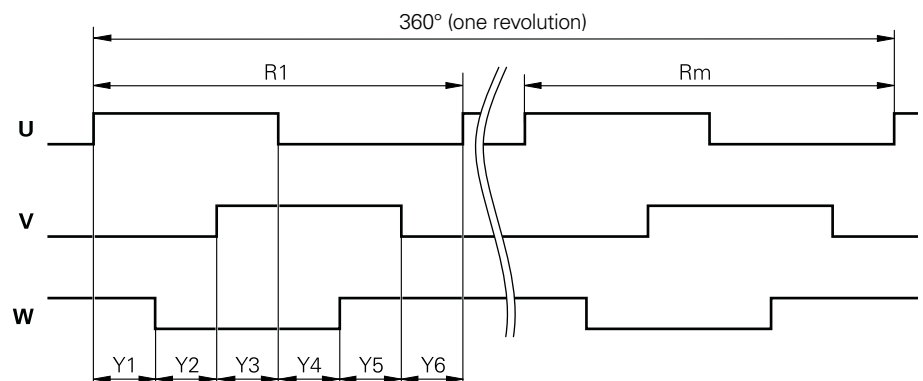

Input circuitry of subsequent electronics

For incremental, reference-mark and commutation signals

Dimensioning

$IC_1 = 74HC14$ CMOS

$R = 2.7 \text{ k}\Omega$

$C = 25 \text{ pF}$

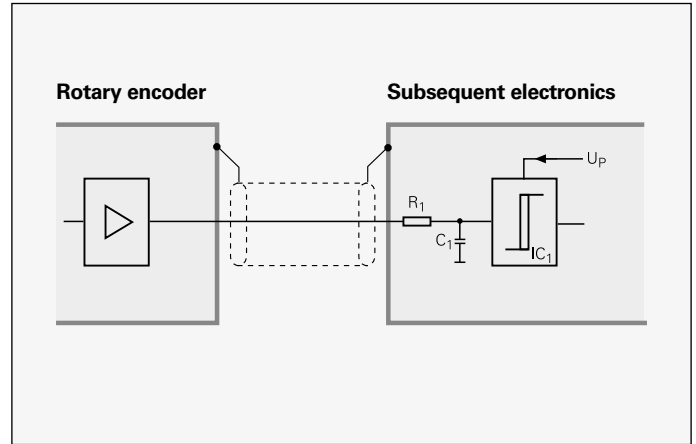

R35i pin layout

15-pin PCB connector															
	Voltage supply		Incremental signals				Reference mark signal		Commutation signals						
	13	14	1	2	3	4	5	6	7	8	9	10	11	12	
PP/0	U_P	0V	U_{a1}	-	U_{a2}	-	U_{a0}	-	-	-	-	-	-	-	
PP/PP	U_P	0V	U_{a1}	-	U_{a2}	-	U_{a0}	-	U	-	V	-	W	-	

Vacant pins must not be used!

RCML15 pin layout

8-pin PCB connector									
Interface	Voltage supply		Incremental signals		Reference mark signal	Commutation signals			
	4	1	3	5	2	6	7	8	
PP/0	U_P	0V	U_{a1}	U_{a2}	U_{a0}	-	-	-	
PP/PP	U_P	0V	U_{a1}	U_{a2}	U_{a0}	U	V	W	

Vacant pins must not be used!

Encoder cable

Encoder cable R35i rotary encoder		With one 15-pin PCB connector (cable cut off) Foil shield with drain wire (cut off at end of cable sheath) Temperature range $-30\text{ }^{\circ}\text{C}$ to $105\text{ }^{\circ}\text{C}$ (rigid configuration)	
Cable length L 0.5 m 1.0 m		Without commutation signals 679489-02 679489-04	With commutation signals 606544-02 606544-04
Pin	Signal function	PVC cable \varnothing 4.6 mm (4x2 AWG28)	PVC cable \varnothing 6 mm (8x2 AWG28)
1	U_{a1}	Yellow	Yellow
2	$\overline{U_{a1}}$	White/Yellow	White/Yellow
3	U_{a2}	Blue	Blue
4	$\overline{U_{a2}}$	WH/BL	WH/BL
5	U_{a0}	Orange	Orange
6	$\overline{U_{a0}}$	White/Orange	White/Orange
7	U	–	Green
8	\overline{U}	–	White/Green
9	V	–	Brown
10	\overline{V}	–	White/Brown
11	W	–	White
12	\overline{W}	–	White/Gray
13	U_P	Red	Red
14	0V	Black	Black
15	Vacant	–	Gray Violet*

Encoder cable RCML15 rotary encoder		With one PCB connector, 8-pin (cable cut off) Foil shield with drain wire (cut off at end of cable sheath) Temperature range $-30\text{ }^{\circ}\text{C}$ to $105\text{ }^{\circ}\text{C}$ (rigid configuration)	
Cable length L 0.15 m 0.5 m 1.0 m		Without commutation signals 639110-03 639110-06 639110-02	With commutation signals 619845-02 619845-12 619845-04
Pin	Signal function	PVC cable \varnothing 4.6 mm (4x2 AWG28)	PVC cable \varnothing 4.6 mm (4x2 AWG28)
1	0V	Black	Black
2	U_{a0}	Orange	Orange
3	U_{a1}	Yellow	Yellow
4	U_P	Red	Red
5	U_{a2}	Blue	Blue
6	U	–	Green
7	V	–	Brown
8	W	–	White
		Green*, brown*, white*	

* To prevent damage to the encoders, insulate any unused wires

General mechanical information

Certified by Nationally Recognized Testing Laboratory (NRTL)

The R35i and RCML15 rotary encoders comply with safety regulations as per UL for the USA and as per CSA for Canada.

RoHS

HEIDENHAIN has tested the products for safety of the materials as per European Directives 2002/95/EC (RoHS) and 2002/96/EC (WEEE). For a Manufacturer's Declaration on RoHS, please refer to your sales agency.

Acceleration

The encoders are subject to various types of acceleration during operation and mounting.

• Vibration

The encoders are qualified on a test stand to operate with the acceleration values listed in the Specifications at frequencies from 55 to 2000 Hz in accordance with EN 60068-2-6. However, if the application or poor mounting causes long-lasting resonant vibration, it can limit performance or even damage the encoder. **Comprehensive tests of the entire system are therefore required.**

• Shock

On a test stand for non-repetitive semi-sinusoidal shock, the encoders are qualified for acceleration values and durations listed in the Specifications in accordance with EN 60068-2-27. This does not include **permanent shock loads**, which **must be tested in the application**.

The **maximum angular acceleration** is 10^5 rad/s^2 (DIN 32878). This is the highest permissible acceleration at which the rotor will rotate without damage to the encoder. A sufficient safety factor is to be determined through system tests. For angular accelerations $\geq 10^4 \text{ rad/s}^2$, HEIDENHAIN recommends the use of an adhesive bond on the shaft (see Chapter *Mounting*).

Protection against contact (EN 60529)

After encoder installation, all rotating parts must be protected against accidental contact during operation.

Protection (EN 60 529)

The R35i and RCML15 rotary encoders fulfill the specified degree of protection—see *Specifications*—for cable outlet and housing (R35i) when plug is engaged.

Conditions for longer storage times

To ensure storage times beyond 12 months, HEIDENHAIN recommends the following:

- Leave the encoders in the original packaging.
- The storage location should be dry, free of dust, and temperature regulated as well as free of vibration, mechanical shock or chemical influences.

Temperature ranges

For the unit in its packaging, the storage temperature range is $-30 \text{ }^\circ\text{C}$ to $+65 \text{ }^\circ\text{C}$. The operating temperature range indicates the temperatures the encoder can reach during operation in the actual installation environment. The function of the encoder is guaranteed within this range (DIN 32878). The operating temperature is measured at the measuring point (see *Dimension drawing*) and must not be confused with the ambient temperature. The temperature of the encoder is influenced by the specific installation, the ambient temperature and encoder's own heat generation.

System tests

As a rule, the R35i and RCML15 rotary encoders are integrated as components in the total system. Such applications require comprehensive tests of the entire system regardless of the specifications of the encoder. The specifications shown in this brochure apply to the specific encoder, not to the complete system. Any operation of the encoder outside of the specified range or for any applications other than the intended applications is at the user's own risk.

Mounting

The work steps and dimensions valid for mounting are available in this catalog and in the installation videos at www.renco.com

Changes to the encoder

The function of the R35i and RCML15 rotary encoders is ensured only in unmodified condition. Any changes, even minor ones, can impair the operation and reliability of the encoders, and result in a loss of warranty. This also includes the use of additional retaining compounds, lubricants (e.g. for screws) or adhesives not explicitly prescribed. In case of doubt, we recommend contacting HEIDENHAIN in Traunreut.

Mounting the R35i

Mounting and commissioning is to be conducted by a qualified specialist under compliance with local safety regulations. In addition, the machine manufacturer or design engineer himself must define the other data required for final assembly. Do not engage or disengage any connections while under power. The system must be disconnected from power!

Avoid direct contact of aggressive media with the connector. Do not clean the encoder with organic solvents like thinners, alcohol, or gasoline. Disassembly in reverse order with identical mounting conditions (mounting tolerances and temperature). You can also download installation instructions from www.renco.com.

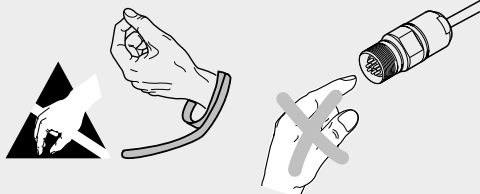

Note the ESD information

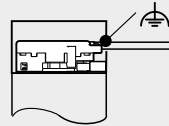

Use conductive housing with shield connection for CE

Mounting the R35i with incremental signals

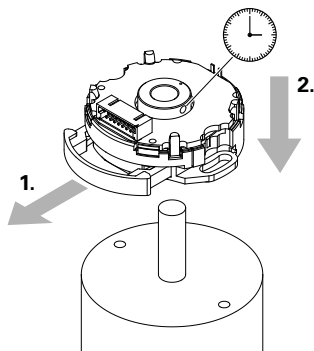

1st step

Ensure that the setscrew for shaft fastening is at 3 o'clock (*reference mark position lies in the range of $\pm 10^\circ$ mechanical*) and the slide-lock mechanism (1) is pulled out as far as it will go. Slide the encoder (2) onto the motor shaft.

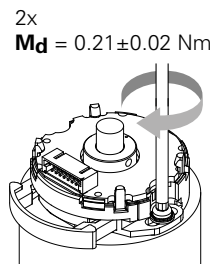

2x
 $M_d = 0.21 \pm 0.02 \text{ Nm}$

2nd step

Tighten the mounting screws finger-tight on both sides. Then tighten them with the required torque.

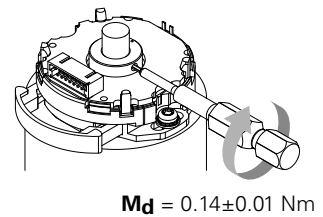

$M_d = 0.14 \pm 0.01 \text{ Nm}$

3rd step

Tighten the setscrew using the required torque.

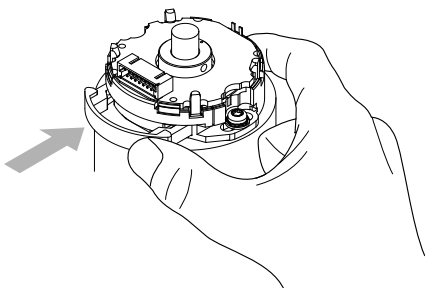

4th step

Holding both the flange and the slide-lock mechanism, push the slide-lock mechanism completely in.

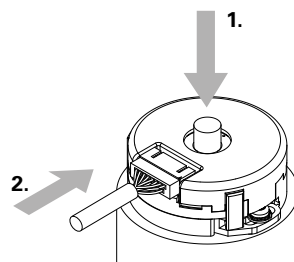

5th step

Mount the encoder housing (1) and connect the cable (2). Do not engage or disengage any connections while under power.

Mounting the R35i with static adjustment of the commutation signals

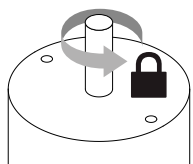

1st step

Bring the rotor to the desired position and lock it. Provide the motor winding U with sufficient DC voltage and current.

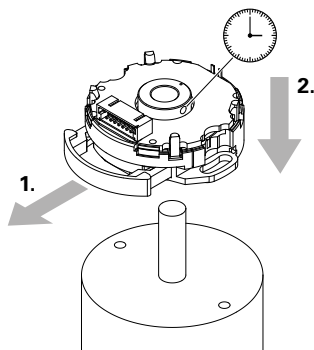

2nd step

Ensure that the setscrew for shaft fastening is at 3 o'clock (*commutation signal U lies in the range of $\pm 10^\circ$ mechanical*) and the slide-lock mechanism (1) is pulled out as far as it will go. Slide the encoder (2) onto the motor shaft.

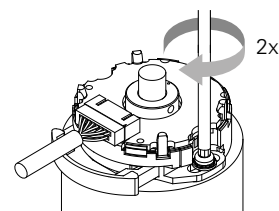

3rd step

Tighten the mounting screws on both sides loosely enough so that the encoder flange can still be rotated by hand.

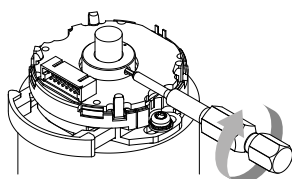

$M_d = 0.14 \pm 0.01$ Nm

4th step

Tighten the setscrew using the required torque.

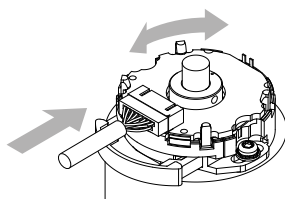

5th step

Connect the test cable without power to the encoder and then provide power. Turn the flange until the commutation signal U changes levels. Then turn back in the other direction until the level jumps back.

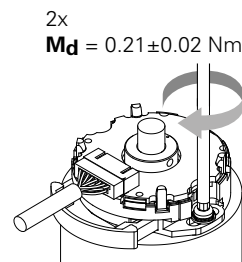

$M_d = 0.21 \pm 0.02$ Nm

6th step

At the midpoint of the switching edges of the U signal, tighten the flange mounting screws using the required torque.

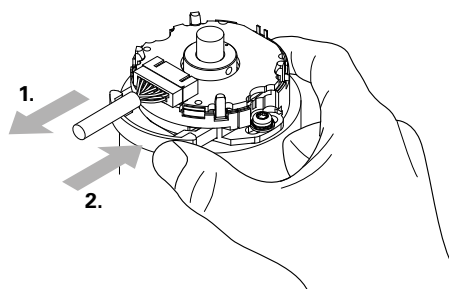

7th step

Switch the encoder power off and unplug the test cable (1). Holding both the flange (2) and the slide-lock mechanism, push the slide-lock mechanism completely in.

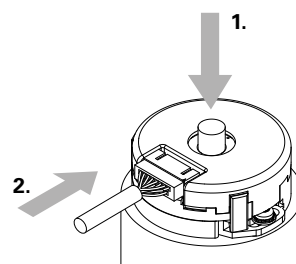

8th step

Mount the encoder housing (1) and connect the cable (2). Do not engage or disengage any connections while under power.

Mounting the R35i with dynamic adjustment of the commutation signals

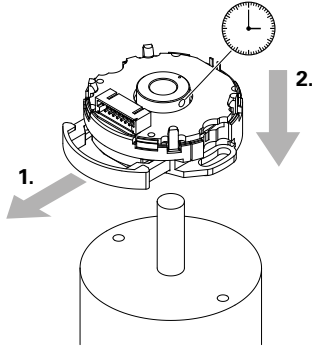

1st step

Ensure that the setscrew for shaft fastening is at 3 o'clock (*commutation signal U lies in the range of $\pm 10^\circ$ mechanical*) and the slide-lock mechanism (1) is pulled out as far as it will go. Slide the encoder (2) onto the motor shaft.

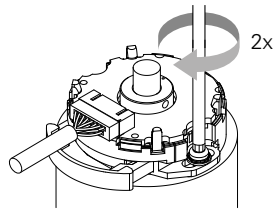

2nd step

Tighten the mounting screws on both sides loosely enough so that the encoder flange can still be rotated by hand.

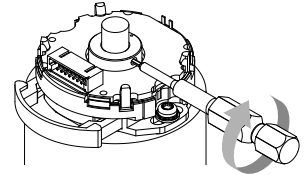

$M_d = 0.14 \pm 0.01 \text{ Nm}$

3rd step

Tighten the setscrew using the required torque.

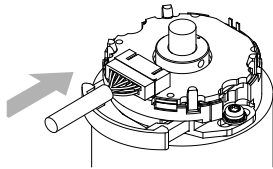

4th step

Connect the test cable without power to the encoder and then provide power. Hold the encoder flange in place and drive the motor in counterclockwise direction.

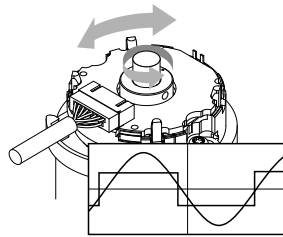

5th step

Rotate the encoder flange until the switch point of the commutation signal U and the zero crossover of the motor winding's electronic commutation coincide. Drive the motor for one minute at a speed of < 500 rpm (*wear between the encoder shaft and slide-lock mechanism*).

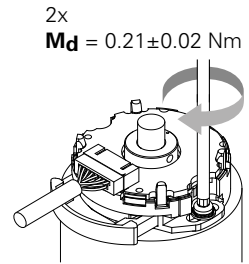

$M_d = 0.21 \pm 0.02 \text{ Nm}$

6th step

In this position with the commutation signal U aligned, tighten the flange mounting screws using the required torque.

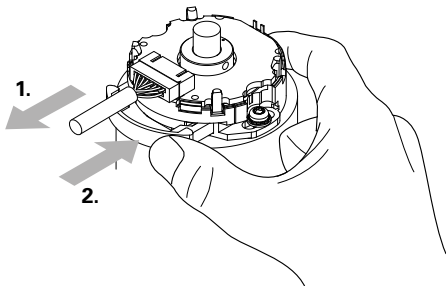

7th step

Switch the encoder power off and unplug the test cable (1). Holding both the flange (2) and the slide-lock mechanism, push the slide-lock mechanism completely in.

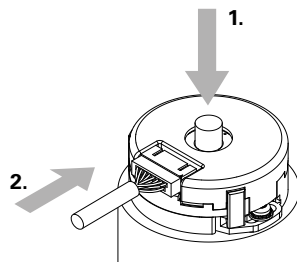

8th step

Mount the encoder housing (1) and connect the cable (2). Do not engage or disengage any connections while under power.

Mounting the RCML15

Mounting and commissioning is to be conducted by a qualified specialist under compliance with local safety regulations. In addition, the machine manufacturer or design engineer must define further data required for final assembly. Do not engage or disengage any connections while under power. The system must be disconnected from power!

Avoid direct contact of aggressive media with the connector. Do not clean the encoder with organic solvents like thinners, alcohol, or benzene. Disassemble in reverse order with identical mounting conditions (mounting tolerances and temperature). You can also download installation instructions from www.renco.com.

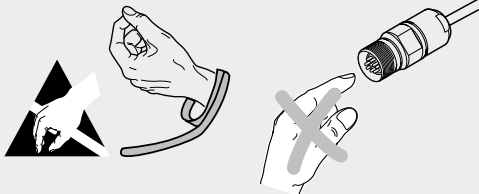

Note the ESD information

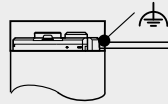

Use conductive housing with shield connection for CE

Mounting the RCML15 with incremental signals

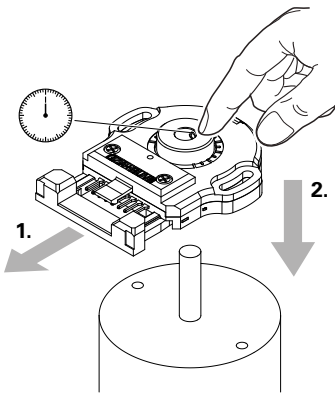

1st step

Ensure that the setscrew for shaft fastening is at 12 o'clock (*reference mark position lies within $\pm 10^\circ$ mechanical*) and the slide-lock mechanism (1) is pulled out as far as it will go. Slide the encoder (2) onto the motor shaft until the flange contacts with the bearing surface. Press only on the encoder shaft.

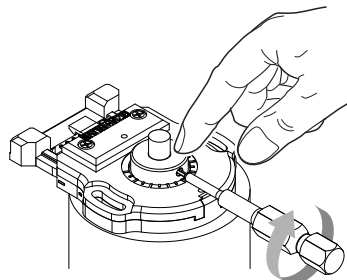

$M_d = 0.14 \pm 0.01 \text{ Nm}$

2nd step

Press with a force of 0.5 kg onto the encoder shaft. Then reduce the force to 0.25 kg and tighten the setscrew using the required torque.

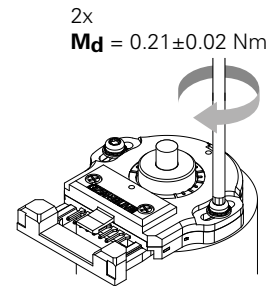

2x
 $M_d = 0.21 \pm 0.02 \text{ Nm}$

3rd step

Tighten the mounting screws finger-tight on both sides. Then tighten them with the required torque.

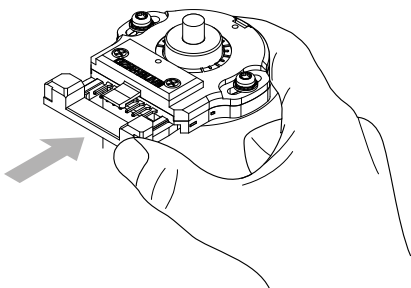

4th step

Holding both the flange and the slide-lock mechanism, press the slide-lock mechanism completely in.

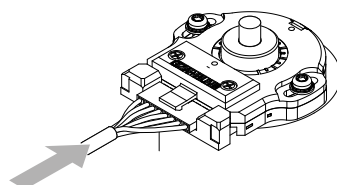

5th step

Connect the cable. Do not engage or disengage any connections while under power.

Mounting the RCML15 with static adjustment of the commutation signals

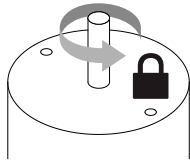

1st step

Bring the rotor to the desired position and lock it. Provide the motor winding U with sufficient DC voltage and current.

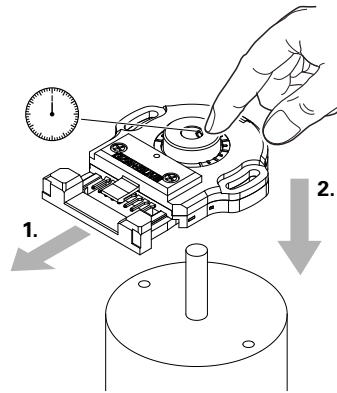

2nd step

Ensure that the setscrew for shaft fastening is at 12 o'clock (*commutation signal U lies in the range of $\pm 10^\circ$ mechanical*) and the slide-lock mechanism (1) is pulled out as far as it will go. Slide the encoder (2) onto the motor shaft until the flange contacts with the bearing surface. Press only on the encoder shaft.

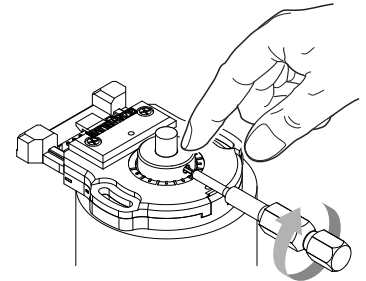

$M_d = 0.14 \pm 0.01 \text{ Nm}$

3rd step

Press with a force of 0.5 kg onto the encoder shaft. Then reduce the force to 0.25 kg and tighten the setscrew using the required torque.

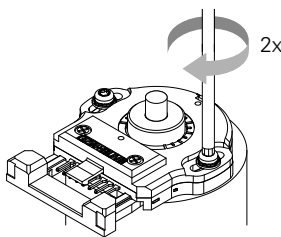

4th step

Tighten the mounting screws on both sides loosely enough so that the encoder flange can still be rotated by hand.

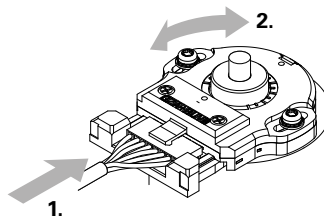

5th step

Connect the test cable without power to the encoder and then provide power. Turn the flange until the commutation signal U changes levels. Then turn back in the other direction until the level jumps back.

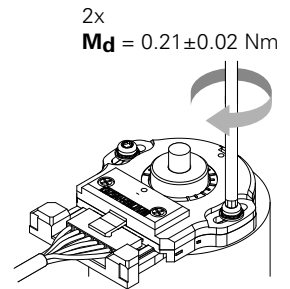

$M_d = 0.21 \pm 0.02 \text{ Nm}$

6th step

At the midpoint of the switching edges U, tighten the flange mounting screws using the required torque.

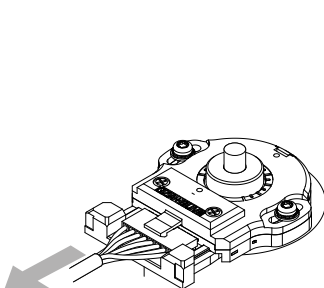

7th step

Switch the encoder power off and unplug the test cable.

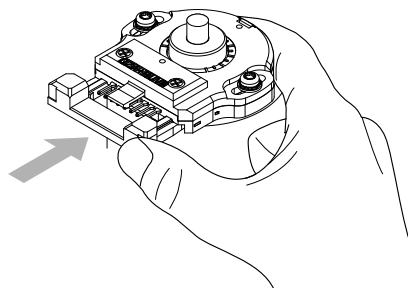

8th step

Holding both the flange and the slide-lock mechanism, push the slide-lock mechanism completely in.

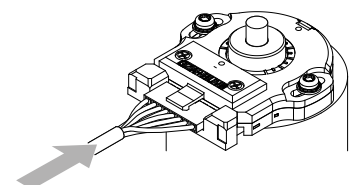

9th step

Connect the cable. Do not engage or disengage any connections while under power.

Mounting the RCML15 with dynamic adjustment of the commutation signals

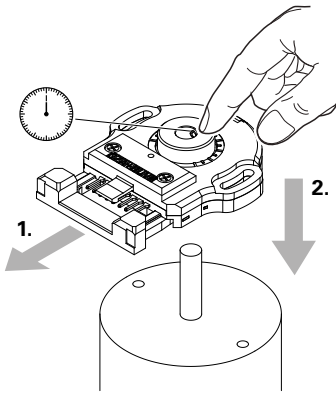

1st step

Ensure that the setscrew for shaft fastening is at 12 o'clock (*commutation signal U lies in the range of $\pm 10^\circ$ mechanical*) and the slide-lock mechanism (1) is pulled out as far as it will go. Slide the encoder (2) onto the motor shaft until the flange contacts with the bearing surface. Press only on the encoder shaft.

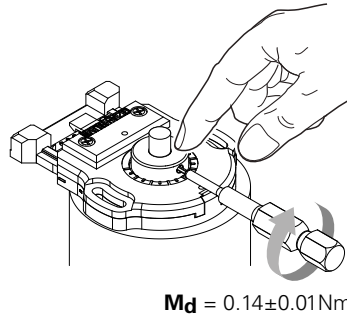

$M_d = 0.14 \pm 0.01 \text{ Nm}$

2nd step

Press with a force of 0.5 kg onto the encoder shaft. Then reduce the force to 0.25 kg and tighten the setscrew using the required torque.

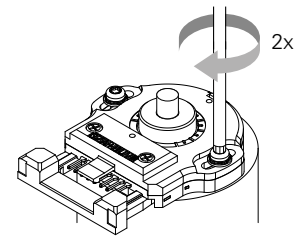

3rd step

Tighten the mounting screws on both sides loosely enough so that the encoder flange can still be rotated by hand.

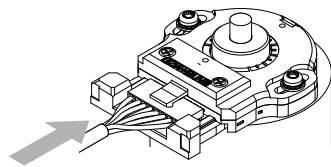

4th step

Connect the test cable without power to the encoder and then provide power. Hold the encoder flange in place and drive the motor in counterclockwise direction.

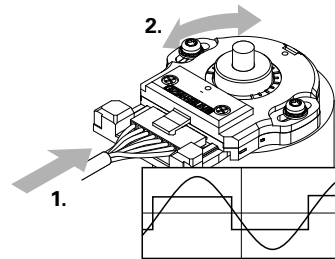

5th step

Rotate the encoder flange until the switch point of the commutation signal U and the zero crossover of the motor winding's EMF signal coincide. Drive the motor for one minute at a speed of $< 500 \text{ rpm}$ (*wear between the encoder shaft and slide-lock mechanism*).

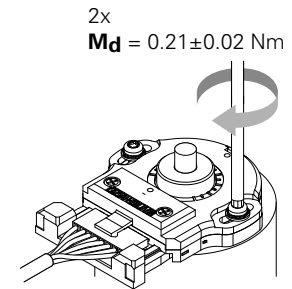

6th step

In this position with the commutation signal U aligned, tighten the flange mounting screws using the required torque.

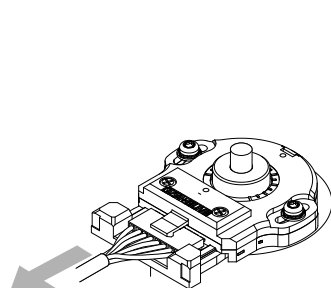

7th step

Switch the encoder power off and unplug the test cable.

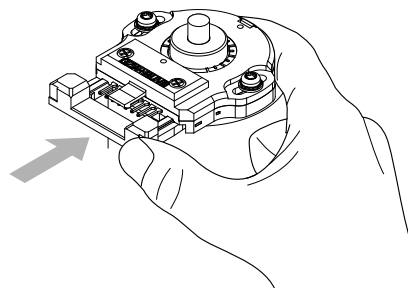

8th step

Holding both the flange and the slide-lock mechanism, push the slide-lock mechanism completely in.

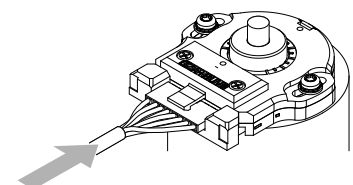

9th step

Connect the cable. Do not engage or disengage any connections while under power.

Adhesive bond for shaft coupling

For angular accelerations $\geq 10^4 \text{ rad/s}^2$, HEIDENHAIN recommends the use of an adhesive bond on the shaft.

Proceed as follows:

- Remove any oil, grease or other impurities from the shaft.
 - Apply Loctite Primer T to the motor shaft.
 - Mount the rotary encoder according to the instructions. For the R35i, do not mount the housing at this time.
 - Apply a small amount of Loctite 290 to the gap between the encoder shaft and motor shaft on the side opposite to the setscrew. Remove any excessive adhesive.
 - If you use Loctite 290 adhesive together with Primer T, a hardness of approx. 25 % will be reached within 15 minutes. Final hardness is reached within one hour. For more information on the application and hardening of the adhesive, visit the manufacturer's website: <http://tds.loctite.com/tds5/docs/290-EN.pdf>
 - *R35i*: Mount the encoder housing and connect the cable.
- Proceed as follows to loosen an adhesive bond for the shaft connection:
- *R35i*: Remove the encoder housing.
 - Apply Debonder-Cleanup Agent X / 8, P / N 06100 from Pacer Technologies to the bond seam between the motor shaft and encoder shaft. Let it work for about 30 to 40 minutes so that the debonding agent can penetrate the Loctite adhesive bond.
 - The encoder is removed in the opposite order from which it was mounted.
 - Remove any remaining debonding agent or adhesive from the motor shaft and encoder shaft.
 - We recommend that you then conduct an electrical test of the encoder using the recommended testing and measuring equipment to rule out any damage.

Mounting accessories

Be sure to check the torque setting and wear of the bits regularly.

Screwdriver

When using screwdrivers with adjustable torque, ensure that they comply with DIN EN ISO 6789 and therefore fulfill the required tolerances for torque values.

Adjustable torque
0.02 Nm to 0.3 Nm
ID 350379-10



Screwdriver bit ("4 spline")

For shaft fastening

RCML15: For all shaft diameters

R35i: For the following shaft diameters
4 mm, 5 mm, 6 mm, 8 mm
1/8, 1/8+, 3/16, 3/16+, 1/4, 1/4+,
5/16, 5/16+ inch



Screwdriver bit set contains the following parts:

- 1/4-inch adapter with "4-spline" (0.048) bit from Bristol
- Wrench for changing bits
- Ten "4-spline" replacement bits (0.048)

ID 825869-01

Screwdriver bit hexagonal, width A/F 0.89 mm

For the hub setscrew for the following shaft diameters: 3/8 or 3/8+ inch
ID 756768-43



Screwdriver bit Torx T8

For R35i flange mounting screws (FOKAA1: H/SH/C/SC) and RCML15
ID 350378-11

Screwdriver bit hexagonal, width A/F 3/32 inch

For R35i flange mounting screws (FOKAA1: H4/SH4/C4/SC4)
ID 756768-48

Mounting aid

For disengaging the PCB connector.
ID 1075573-01



For replacement set screws for shaft clamping, please refer to your sales agency.

Diagnostic and testing equipment

PWM 20

Together with the ATS adjusting and testing software, the PWM 20 phase angle measuring unit serves for diagnosis and adjustment of RENCO and HEIDENHAIN encoders.



For more information, see the *PWM 20 / ATS Software* Product Information sheet.

	PWM 20
Encoder input	<ul style="list-style-type: none"> • EnDat 2.1 or EnDat 2.2 (absolute value with/without incremental signals) • DRIVE-CLiQ • Fanuc Serial Interface • Mitsubishi high speed interface • Yaskawa Serial Interface • Panasonic serial interface • SSI • 1 V_{PP}/TTL/11 μA_{PP} • HTL (via signal adapter)
Interface	USB 2.0
Voltage supply	AC 100 V to 240 V or DC 24 V
Dimensions	258 mm x 154 mm x 55 mm

	ATS
Languages	Choice between English and German
Functions	<ul style="list-style-type: none"> • Position display • Connection dialog • Diagnostics • Mounting wizard for EBI/ECI/EQI, LIP 200, LIC 4000 and others • Additional functions (if supported by the encoder) • Memory contents
System requirements and recommendations	PC (dual-core processor, > 2 GHz) RAM > 2 GB Windows operating systems XP, Vista, 7 (32-bit/64-bit), 8 200 MB free space on hard disk

DRIVE-CLiQ is a registered trademark of Siemens Aktiengesellschaft

The **PWM 9** is a universal measuring device for checking and adjusting HEIDENHAIN incremental encoders. Expansion modules are available for checking the various types of encoder signals. The values can be read on an LCD monitor while soft keys provide ease of operation.



	PWM 9
Inputs	Expansion modules (interface boards) for 11 μA _{PP} ; 1 V _{PP} ; TTL; HTL; EnDat*/SSI*/commutation signals *No display of position values or parameters
Functions	<ul style="list-style-type: none"> • Measures signal amplitudes, current consumption, operating voltage, scanning frequency • Graphically displays incremental signals (amplitudes, phase angle and on-off ratio) and the reference-mark signal (width and position) • Displays symbols for the reference mark, fault-detection signal, counting direction • Universal counter, interpolation selectable from single to 1024-fold • Adjustment support for exposed linear encoders
Outputs	<ul style="list-style-type: none"> • Inputs are connected through to the subsequent electronics • BNC sockets for connection to an oscilloscope
Voltage supply	DC 10 V to 30 V, max. 15 W
Dimensions	150 mm x 205 mm x 96 mm

Testing and inspecting equipment specific to the R35i / RCML15

ID number	Designation	Function
1041735-01	R35i / RCML15 traversing device	Setup fixture including mounting accessories
1033936-xx	Exchangeable shaft-bearing assembly, each item can be ordered separately	<i>Var 01:</i> Shaft diameter 1/8" <i>Var 02:</i> Shaft diameter 3/16" <i>Var 03:</i> Shaft diameter 1/4" <i>Var 04:</i> Shaft diameter 5/16" <i>Var 05:</i> Shaft diameter 3/8" <i>Var 06:</i> Shaft diameter 4 mm <i>Var 07:</i> Shaft diameter 5 mm <i>Var 08:</i> Shaft diameter 6 mm <i>Var 09:</i> Shaft diameter 8 mm
820193-01	Adapter box including power supply unit and connection template	<ul style="list-style-type: none"> • Switchover between main signal tracks and commutation signals • Adaptation of single-ended output signals to the TTL inputs of the PWM9/20
816480-01	Encoder cable 03S17 1,00 40 33 0,00 3VB015 ...	Cable between R35i and adapter box
1042917-01	Encoder cable 03S17 1,00 40 33 0,00 91B008 ...	Cable between RCML15 and adapter box
825426-02	Adapter cable APK 03 08 2,00 51B015 02S012-03 BK .. 01	Cable between adapter box and PWM 9
517673-02	Connecting cable 16B015 16S015 10 2,00 03 .. BK	Cable between adapter box and PWM 20

The **adapter box** ID 820193-01 is required for testing the R35i or RCML15 rotary encoder. You use it to adapt the various interface versions of the R35i and RCML15 and their possible combinations for incremental and commutation signals to the TTL interface (RS-422) of PWM 9 / PWM 20.



HEIDENHAIN

DR. JOHANNES HEIDENHAIN GmbH

Dr.-Johannes-Heidenhain-Straße 5

83301 Traunreut, Germany

☎ +49 8669 31-0

FAX +49 8669 32-5061

E-mail: info@heidenhain.de

www.heidenhain.de

Vollständige und weitere Adressen siehe www.heidenhain.de
For complete and further addresses see www.heidenhain.de

DE	HEIDENHAIN Vertrieb Deutschland 83301 Traunreut, Deutschland ☎ 08669 31-3132 FAX 08669 32-3132 E-Mail: hd@heidenhain.de	ES	FARRESA ELECTRONICA S.A. 08028 Barcelona, Spain www.farresa.es	PL	APS 02-384 Warszawa, Poland www.heidenhain.pl
	HEIDENHAIN Technisches Büro Nord 12681 Berlin, Deutschland ☎ 030 54705-240	FI	HEIDENHAIN Scandinavia AB 01740 Vantaa, Finland www.heidenhain.fi	PT	FARRESA ELECTRÓNICA, LDA. 4470 - 177 Maia, Portugal www.farresa.pt
	HEIDENHAIN Technisches Büro Mitte 07751 Jena, Deutschland ☎ 03641 4728-250	FR	HEIDENHAIN FRANCE sarl 92310 Sèvres, France www.heidenhain.fr	RO	HEIDENHAIN Reprezentantă Romania Braşov, 500407, Romania www.heidenhain.ro
	HEIDENHAIN Technisches Büro West 44379 Dortmund, Deutschland ☎ 0231 618083-0	GB	HEIDENHAIN (G.B.) Limited Burgess Hill RH15 9RD, United Kingdom www.heidenhain.co.uk	RS	Serbia → BG
	HEIDENHAIN Technisches Büro Südwest 70771 Leinfelden-Echterdingen, Deutschland ☎ 0711 993395-0	GR	MB Milionis Vassilis 17341 Athens, Greece www.heidenhain.gr	RU	OOO HEIDENHAIN 115172 Moscow, Russia www.heidenhain.ru
	HEIDENHAIN Technisches Büro Südost 83301 Traunreut, Deutschland ☎ 08669 31-1345	HK	HEIDENHAIN LTD Kowloon, Hong Kong E-mail: sales@heidenhain.com.hk	SE	HEIDENHAIN Scandinavia AB 12739 Skärholmen, Sweden www.heidenhain.se
		HR	Croatia → SL	SG	HEIDENHAIN PACIFIC PTE LTD. Singapore 408593 www.heidenhain.com.sg
AR	NAKASE SRL. B1653AOX Villa Ballester, Argentina www.heidenhain.com.ar	HU	HEIDENHAIN Kereskedelmi Képviselet 1239 Budapest, Hungary www.heidenhain.hu	SK	KOPRETINA TN s.r.o. 91101 Trenčín, Slovakia www.kopretina.sk
AT	HEIDENHAIN Techn. Büro Österreich 83301 Traunreut, Germany www.heidenhain.de	ID	PT Servitama Era Toolsindo Jakarta 13930, Indonesia E-mail: ptset@group.gts.co.id	SL	NAVO d.o.o. 2000 Maribor, Slovenia www.heidenhain.si
AU	FCR Motion Technology Pty. Ltd Laverton North 3026, Australia E-mail: vicsales@fcrmotion.com	IL	NEUMO VARGUS MARKETING LTD. Tel Aviv 61570, Israel E-mail: neumo@neumo-vargus.co.il	TH	HEIDENHAIN (THAILAND) LTD Bangkok 10250, Thailand www.heidenhain.co.th
BE	HEIDENHAIN NV/SA 1760 Roosdaal, Belgium www.heidenhain.be	IN	HEIDENHAIN Optics & Electronics India Private Limited Chetpet, Chennai 600 031, India www.heidenhain.in	TR	T&M Mühendislik San. ve Tic. LTD. ŞTİ. 34775 Y. Dudullu – Ümraniye-Istanbul, Turkey www.heidenhain.com.tr
BG	ESD Bulgaria Ltd. Sofia 1172, Bulgaria www.esd.bg	IT	HEIDENHAIN ITALIANA S.r.l. 20128 Milano, Italy www.heidenhain.it	TW	HEIDENHAIN Co., Ltd. Taichung 40768, Taiwan R.O.C. www.heidenhain.com.tw
BR	DIADUR Indústria e Comércio Ltda. 04763-070 – São Paulo – SP, Brazil www.heidenhain.com.br	JP	HEIDENHAIN K.K. Tokyo 102-0083, Japan www.heidenhain.co.jp	UA	Gertner Service GmbH Büro Kiev 01133 Kiev, Ukraine www.heidenhain.ua
BY	GERTNER Service GmbH 220026 Minsk, Belarus www.heidenhain.by	KR	HEIDENHAIN Korea LTD. Gasan-Dong, Seoul, Korea 153-782 www.heidenhain.co.kr	US	HEIDENHAIN CORPORATION Schaumburg, IL 60173-5337, USA www.heidenhain.com
CA	HEIDENHAIN CORPORATION Mississauga, Ontario L5T2N2, Canada www.heidenhain.com	MX	HEIDENHAIN CORPORATION MEXICO 20290 Aguascalientes, AGS., Mexico E-mail: info@heidenhain.com	VE	Maquinaria Diekmann S.A. Caracas, 1040-A, Venezuela E-mail: purchase@diekmann.com.ve
CH	HEIDENHAIN (SCHWEIZ) AG 8603 Schwerzenbach, Switzerland www.heidenhain.ch	MY	ISOSERVE SDN. BHD. 43200 Balakong, Selangor E-mail: sales@isoserve.com.my	VN	AMS Co. Ltd HCM City, Vietnam E-mail: davidgoh@amsvn.com
CN	DR. JOHANNES HEIDENHAIN (CHINA) Co., Ltd. Beijing 101312, China www.heidenhain.com.cn	NL	HEIDENHAIN NEDERLAND B.V. 6716 BM Ede, Netherlands www.heidenhain.nl	ZA	MAFEMA SALES SERVICES C.C. Midrand 1685, South Africa www.heidenhain.co.za
CZ	HEIDENHAIN s.r.o. 102 00 Praha 10, Czech Republic www.heidenhain.cz	NO	HEIDENHAIN Scandinavia AB 7300 Orkanger, Norway www.heidenhain.no		
DK	TPTEKNIK A/S 2670 Greve, Denmark www.tp-gruppen.dk	PH	Machinebanks Corporation Quezon City, Philippines 1113 E-mail: info@machinebanks.com		

